



Fire assessment report



Service penetrations protected with BOSS
FireMastic - HPE sealant

Sponsor: Boss Products Australia Pty Ltd

Report number: FAS190335 Revision: R1.2

Issued date: 11 June 2024 Expiry date: 31 July 2028

Quality management

Version	Date	Information about the report			
R1.0	Issue: 31 May 2023	Reason for issue	Draft report issued for review and comment		
		Prepared by	Reviewed by	Authorised by	
		Name	Mohammed Mutafi	Omar Saad	Omar Saad
R1.1	Issue: 7 July 2023	Reason for issue	Initial issue		
		Prepared by	Reviewed by	Authorised by	
		Name	Mohammed Mutafi	Omar Saad	Omar Saad
R1.2	Issue: 11 June 2024	Reason for issue	Updated based on client comments		
	Expiry: 31 July 2028	Prepared by	Reviewed by	Authorised by	
		Name	Mohammed Mutafi	Omar Saad	Omar Saad
		Signature			

Executive summary

This report documents the findings of the assessment undertaken to determine the expected fire resistance level (FRL) of various combustible pipes, insulated metal pipes, cables, cable bundles, and Heating, Ventilation and Cooling (HVAC) bundles penetrating wall and floor separating elements protected by BOSS FireMastic – HPE sealant. This assessment is conducted in accordance with AS 1530.4:2014 and, in general accordance with AS 4072.1:2005.

The analysis in sections 5 to 7.10 of this report found that the proposed systems, together with the described variations, are expected to achieve the FRLs as shown in Table 1 in accordance with AS 1530.4:2014.

Table 1 Assessment outcomes

Item	Proposed system	Assessment outcome
1.	Assessment outcome of combustible pipes installed in flexible wall systems	Table 11
2.	Assessment outcome of combustible pipes in rigid wall systems	Table 13
3.	Assessment outcome of combustible pipes in CLT walls	Table 15
4.	Assessment outcome of combustible pipes in Masonry wall with double layer of 50 mm thick "BOSS Fire Batt" aperture – Factory applied "BOSS Ablative Coating" to both faces and PS coating to exposed face.	Table 17
5.	Assessment outcomes of Insulated metal pipes fitted in minimum 116 mm thick flexible wall	Table 19
6.	Assessment outcome of insulated metal pipe penetrating double layer of 50 mm thick BOSS fire batt installed in a minimum 116 mm flexible and rigid walls	Table 21
7.	Assessment outcome of combustible pipes in 235 mm thick plasterboard ceiling system	Table 23
8.	Assessment outcome of combustible pipes in AAC floor system	Table 25
9.	Assessment outcome of insulated metal pipes in concrete slab	Table 29
10.	Assessment outcome of cables in 90 mm flexible or rigid wall	Table 33
11.	Assessment outcome of cables in 116 mm flexible or rigid wall	Table 35
12.	Assessment outcome of cables in rigid wall	Table 37
13.	Assessment outcome of cables in ceiling system	Table 39
14.	Assessment outcome of cables in AAC floor	Table 41
15.	Assessment outcome of cables in concrete	Table 43
16.	Assessment outcome of HVAC services in 90 mm flexible wall system	Table 50
17.	Assessment outcome of HVAC services in 116 mm flexible wall system	Table 52
18.	Assessment of HVAC services in AAC wall system (double mesh)	Table 54
19.	Assessment of HVAC services in CLT wall	Table 56
20.	Assessment of HVAC services in ceiling system	Table 58
21.	Assessment outcome of HVAC services in concrete slab	Table 60
22.	Assessment outcome of HVAC service penetration in ComFlor60	Table 62

The variations and outcome of this assessment are subject to the limitations and requirements described in sections 2, 3 and 9 of this report. The results of this report are valid until 31 May 2028.

Contents

1.	Introduction.....	6
2.	Framework for the assessment.....	6
2.1	Assessment approach.....	6
2.2	Compliance with the National Construction Code.....	7
2.3	Declaration.....	7
3.	Requirements and limitations of this assessment.....	7
4.	Description of the specimen and variations.....	8
4.1	Description of assessed systems.....	8
4.2	Referenced test data.....	12
4.3	Variations to the tested systems.....	13
5.	Relevance of EN 1366-3:2009 test data with respect to AS 1530.4:2014.....	21
6.	Assessment 1 – Pipe services protected with BOSS FireMastic–HPE sealant.....	24
6.1	Description of variation.....	24
6.2	Methodology.....	24
6.3	Assessment of various combustible pipes in minimum 116 mm thick flexible wall systems or rigid walls.....	24
6.4	Assessment of various combustible pipes in minimum 75 mm thick rigid wall systems.....	36
6.5	Assessment of various combustible pipes in minimum 130 mm thick CLT wall systems.....	40
6.6	Assessment of various combustible pipes in Masonry wall with double layer of 50 mm thick “BOSS Fire Batt” aperture – Factory applied “BOSS Ablative Coating” to both faces and PS coating to exposed face.....	41
6.7	Assessment of insulated metal pipes in minimum 116 mm thick flexible wall system.....	43
6.8	Assessment of insulated metal pipes penetrating double layer of 50 mm thick BOSS fire batt installed in a minimum 116 mm flexible and rigid walls.....	48
6.9	Assessment of various combustible pipes in minimum 235 mm thick ceiling systems.....	50
6.10	Assessment of various combustible pipes in minimum 150 mm thick AAC floor.....	51
6.11	Assessment of various combustible pipes in minimum 150 mm thick concrete floor.....	54
6.12	Assessment of insulated metal pipes in a minimum 125 mm concrete slab.....	58
7.	Assessment of various cables protected with BOSS FireMastic–HPE sealant.....	60
7.1	Description of variation.....	60
7.2	Methodology.....	61
7.3	Assessment of various cables in minimum 90 mm flexible or rigid wall protected by BOSS FireMastic-HPE sealant.....	61
7.4	Assessment of various cables in minimum 116 mm flexible or rigid wall protected by BOSS FireMastic-HPE sealant.....	63
7.5	Assessment of various cables in minimum 75 mm rigid wall protected by BOSS FireMastic-HPE sealant.....	65
7.6	Assessment of various cables in minimum 235 mm plasterboard ceiling system protected by BOSS FireMastic-HPE sealant.....	68
7.7	Assessment of various cables in minimum 150 mm thick AAC floor system protected by BOSS FireMastic-HPE sealant.....	69
7.8	Assessment of various cables in minimum 150 mm concrete slab system protected by BOSS FireMastic-HPE sealant.....	73
7.9	Assessment of various cables in minimum 130 mm CLT wall system protected by BOSS FireMastic-HPE sealant.....	75
7.10	Assessment of various cables in minimum 150 mm thick autoclaved blockwork wall system protected with BOSS FireMastic–HPE sealant.....	76
7.11	Proposed construction.....	76
8.	Assessment of various HVAC bundle with or without cables protected with BOSS FireMastic–HPE sealant.....	78
8.1	Description of variation.....	78
8.2	Methodology.....	78
8.3	Assessment of various HVAC bundle with or without cables in minimum 90 mm flexible wall system protected by BOSS FireMastic-HPE sealant.....	79
8.4	Assessment of various HVAC bundle with or without cables in minimum 116 mm flexible wall system protected by BOSS FireMastic-HPE sealant.....	82
8.5	Assessment of various HVAC bundle with or without cables in minimum 75 mm AAC wall system protected by BOSS FireMastic-HPE sealant.....	84
8.6	Assessment of various HVAC bundle with or without cables in minimum 130 mm thick CLT timber wall protected by BOSS FireMastic-HPE sealant.....	87
8.7	Assessment of various HVAC services in minimum 235 mm thick ceiling protected by BOSS FireMastic-HPE sealant.....	88
8.8	Assessment of various HVAC services in minimum 150 mm thick concrete slab protected by BOSS FireMastic-HPE sealant.....	90
8.9	Assessment of HVAC bundle with or without cables in ComFlor60 (Max 130 mm thick / min 70 mm thick).....	92
9.	Validity.....	94
Appendix A	Summary of supporting test data.....	95

1. Introduction

This report documents the findings of the assessment undertaken to determine the expected fire resistance level (FRL) of various combustible pipes, cables, cable bundles, Heating, Ventilation and Cooling (HVAC) bundles and insulated metal pipes penetrating wall and floor separating elements protected by BOSS FireMastic – HPE sealant. This assessment is conducted in accordance with AS 1530.4:2014¹ and in general accordance with AS 4072.1:2005².

This report may be used as evidence of suitability in accordance with the requirements of the relevant National Construction Code (NCC) to support the use of the material, product, form of construction or design as given within the scope of this assessment report. It also references test evidence for meeting deemed to satisfy (DTS) provisions of the NCC that apply to the assessed systems.

This assessment was carried out at the request of Boss Products Australia Pty Ltd.

The sponsor details are included in Table 2.

Table 2 Sponsor details

Sponsor	Address
Boss Products (Australia) Pty Ltd	Unit 1, 16 Atkinson Road, Taren Point, NSW 2229

2. Framework for the assessment

2.1 Assessment approach

An assessment is a professional opinion about the expected performance of a component or element of structure subjected to a fire test.

No specific framework, methodology, standard or guidance documents exists in Australia for undertaking these assessments. We have therefore followed the ‘Guide to undertaking technical assessments of the fire performance of construction products based on fire test evidence’ prepared by the Passive Fire Protection Forum (PFPF) in the UK in 2021³.

This guide provides a framework for undertaking assessments in the absence of specific fire test results. Some areas where assessments may be offered are:

- Where a modification is made to a construction which has already been tested
- The interpolation or extrapolation of results of a series of fire resistance tests, or utilisation of a series of fire test results to evaluate a range of variables in a construction design or a product
- Where, for various reasons – eg size or configuration – it is not possible to subject a construction or a product to a fire test.

Assessments can vary from relatively simple judgements on small changes to a product or construction through to detailed and often complex engineering assessments of large or sophisticated constructions.

This assessment uses established empirical methods and our experience of fire testing similar products to extend the scope of application by determining the limits for the design and performance based on the tested constructions and performances obtained. The assessment is an evaluation of the potential fire resistance performance of the elements in accordance with AS 1530.4:2014.

¹ Standards Australia, 2014, Methods for fire tests on building materials, components, and structures – Part 4: Fire-resistance tests for elements of construction, AS 1530.4:2014, Standards Australia, NSW.

² Standards Australia, 2005, Components for the protection of openings in fire-resistant separating elements: Service penetrations and control joints, AS 4072.1:2005, Standards Australia, NSW.

³ Passive Fire Protection Forum (PFPF), 2021, Guide to undertaking technical assessments of the fire performance of construction products based on fire test evidence, Passive Fire Protection Forum (PFPF), UK.

This assessment has been written using appropriate test evidence generated at accredited laboratories to the relevant test standard. The supporting test evidence has been deemed appropriate to support the manufacturer's stated design.

2.2 Compliance with the National Construction Code

This assessment report has been prepared to meet the evidence of suitability requirements of the NCC 2022⁴ under A5G3 (1) (d). It references test evidence for meeting deemed to satisfy (DTS) provisions of the NCC under A5G5 for fire resistance level that apply to the assessed systems based on Specifications 1 and 2 for fire resistance for building elements.

The proposed details and systems (building elements) in this report are confirmed to be assessed, without the aid of an active fire suppression system, based on prototype tests that are equivalent to or more severe than a standard fire test in accordance with NCC 2022 S1C2(b). It is also confirmed that the differences between the proposed systems and details compared to the tested prototypes are considered minor in accordance with NCC 2022 S1C2(c).

This assessment report may also be used to demonstrate compliance with the requirements for evidence of suitability under the relevant sections of previous versions of the NCC.

2.3 Declaration

The 'Guide to undertaking technical assessments of the fire performance of construction products based on fire test evidence' prepared by the PFPF in the UK requires a declaration from the client. By accepting our fee proposal on 1 March 2023, Boss Products Australia Pty Ltd confirmed that:

- To their knowledge, the variations to the component or element of structure, which is the subject of this assessment, have not been subjected to a fire test to the standard against which this assessment is being made.
- They agree to withdraw this assessment from circulation if the component or element of structure is the subject of a fire test by a test authority in accordance with the standard against which this assessment is being made and the results are not in agreement with this assessment.
- They are not aware of any information that could adversely affect the conclusions of this assessment and – if they subsequently become aware of any such information – they agree to ask the assessing authority to withdraw the assessment.

3. Requirements and limitations of this assessment

- The scope of this report is limited to an assessment of the variations to the tested systems described in section 4.1
- This report details the methods of construction, test conditions and assessed results expected in accordance with AS 1530.4:2014.
- This assessment applies to floor/ceiling systems exposed to fire from below in accordance with the requirements of AS 1530.4:2014, where horizontal elements must be exposed to heat from the underside only.
- This assessment applies to wall systems exposed to fire from each side/one side in accordance with the requirements of AS 1530.4:2014, where vertical elements must be exposed to heat from the direction required to resist fire exposure.
- The FRLs achieved can be extended to timber framed walls. For timber framed walls, it is required that no part of the penetration seal is closer than 100 mm to a stud, the cavity is closed between the penetration seal and the stud.
- This report is only valid for the assessed system/s and must not be used for any other purpose. Any changes with respect to size, construction details, loads, stresses, edge or end conditions – other than those identified in this report – may invalidate the findings of this

⁴ National Construction Code Volumes One and Two - Building Code of Australia 2022, Australian Building Codes Board, Australia

assessment. If there are changes to the system, a reassessment will need to be done by an Accredited Testing Laboratory (ATL) that is accredited to the same nominated standards of this report.

- Support of services in walls and floors must be maintained as per AS 1530.4:2014 and AS 4072.1:2005 requirements.
- While it is recommended that the elastomeric pipe insulation be classified B-s3, d0 in accordance with EN 13501-1⁵ as tested, the achieved results can be extended to cover an insulation material not deemed combustible as determined by AS 1530.1:1994 if they meet this classification.
- The documentation that forms the basis for this report is listed in Appendix A.
- This report has been prepared using information provided by others. Warringtonfire has not verified the accuracy and/or completeness of that information and will not be responsible for any errors or omissions that may have been incorporated into this report as a result.
- This assessment is based on the proposed systems being constructed under comprehensive quality control practices and following appropriate industry regulations and Australian Standards on quality of materials, design of structures, guidance on workmanship and expert handling, placing and finishing of the products on site. These variables are beyond the control and consideration of this report.
- Where rigid walls reference FRL -/120/120 outcomes, FRL -/30/30, FRL -/60/60 and FRL -/90/90 also apply.
- Where concrete floor slabs reference FRL -/120/120 outcomes, FRL -/30/30, FRL -/60/60 and FRL -/90/90 also apply.
- Where concrete floor slabs reference FRL -/240/240 outcomes, FRL -/30/30, FRL -/60/60 and FRL -/90/90, FRL -/120/120, FRL -/180/180 also apply.
- In all cases, the FRL of the assessed service is limited to the FRL of the separating element.

4. Description of the specimen and variations

4.1 Description of assessed systems

The systems assessed in this report include various services protected by BOSS FireMastic-HPE sealant. BOSS FireMastic-HPE sealant is an intumescent, high-pressure exerting fire sealant (graphite based) used to close the gaps formed by the melting of the services that penetrate walls and floors to maintain the integrity and insulation performance of the seal.

The intended use of BOSS FireMastic HPE sealant is to reinstate the fire resistance performance of flexible wall, rigid wall and floor constructions where they are penetrated by services. Table 3 and Table 4 show the details of the vertical and horizontal separating elements considered in this assessment.

It is also noted that FireMastic-300 sealant is used on certain systems. FireMastic-300 is an acrylic intumescent sealant that has fire resistant properties while also being flexible.

The services considered in this assessment are pipes, cables and Heating, ventilation, and air-conditioning (HVAC). The type of pipes includes Unplasticized polyvinyl chloride pipe (UPVC), High density polyethylene pipe (HDPE), Polypropylene pipe (PP), Polyethylene pipe (PE), Polyethylene/aluminum/cross-linked polyethylene composite pressure pipe (PEX-AL-PEX), Crosslinked polyethylene PEX-A, Crosslinked polyethylene PEX-B, Chlorinated polyvinyl chloride (CPVC), Acrylonitrile Butadiene Styrene (ABS), insulated copper and steel pipes.

The cables considered in this assessment include fire alarm cable, RG6 Coax, CAT6, Core security cables, 2C+E TPS, ELV extra low voltage alarm cable, 2C+E, TPS and Power cable-3 core. The assessment includes the cables referenced in EN 1366-3:2009 and listed in Table 30.

⁵ European Committee for Standardization, Fire classification of construction products and building elements - Part 1: Classification using data from reaction to fire tests, EN 13501-1, European Committee for Standardization, Brussels, Belgium.

The assessment also includes HVAC services, which are a combination of pipes and cables.

The specific elements of construction that the system may be used to provide a penetration fire seal for are as follows:

1. Flexible walls must have a minimum thickness as tested, and the construction of the wall should consist of steel studs lined on both faces with one or two layers of fire rated plasterboard. Unless otherwise specified, the cavity of flexible walls must be filled with R2.0 Glasswool Batt insulation, filled up to the aperture of the service. For services tested in walls with two layers of 13 mm thick fire rated plasterboard on both faces, single layer walls are permitted provided that the area around the penetration is built up with an additional layer of fire rated plasterboard and must extend at least 100 mm in all directions from the aperture.
2. Where Shaftwall systems have a single layer of 13 mm or 16 mm fire rated plasterboard on one side of the stud, results from double layer plasterboard systems can apply by adding a secondary localised pattress to the single layer plasterboard side of the system. FRL applicable to the substrate up to FRL -/120/120, however the overall FRL is limited to the FRL of the wall system.
3. FRLs assessed for flexible walls can be applied to the same services penetrating through rigid walls and having the same or greater thicknesses (or localised increased thickness), as applicable, with an established FRL as required, as tested or assessed by an ATL.
4. Timber walls: The wall must have a minimum thickness of 100 mm and consist of solid wood or cross-laminated timber (CLT). The density must be minimum 464 kg/m³ and the adhesive used must be in the family of heat-resistant melamine-urea-formaldehyde. The outer lamella thickness on either side must be equal to or greater than 33 mm.
5. Rigid walls must be minimum 75 mm thick and must be Autoclave Aerated Concrete (AAC) wall, concrete or solid masonry. Thinner rigid walls must be built up on either one or both sides to achieve the minimum thickness required as assessed for the required FRL. The build-up could be fire-rated plasterboard, calcium silicate board, MGO board or BOSS batts and must extend at least 100 mm in all directions from the aperture.
6. FRLs assessed for AAC blockwork walls, Hebel walls and Speedpanel walls can be applied to the same services penetrating through rigid walls having the same or greater thickness, as applicable (including concrete, solid masonry, Speedpanel, Hebel and Korok) with an established FRL as required, tested or assessed by an ATL.
7. Rigid floors: The floor must have a minimum thickness of 150 mm and comprise AAC or concrete with a minimum density of 650 kg/m³. Metal deck and trapezoidal floor slabs like bondek and comflor are permitted, provided that the minimum thickness of the concrete above the ribbed area is 150 mm. Floor elements are required to be otherwise tested or assessed by others for the required fire resistance period.
8. Results obtained in 150 mm AAC floors can be extended to floors systems of greater thickness and density in accordance with section 10 of AS 1530.4:2014, which describes permissible variations. Therefore, minimum 150 mm thick AAC or normal weight concrete floor slabs with a minimum density of 650 kg/m³ are expected to achieve the same fire resistance performance as observed for the tested 150 mm thick AAC floors.
9. Where assessed outcomes reference minimum 150 mm thick concrete floor slabs, thinner traditional concrete floor slabs, bondek and comflor can be used provided there is localised thickening in the form of BOSS Batts applied to the top or bottom of the floor slab with a minimum 100 mm overlap to the edge of the aperture. The FRL of the service will be limited by the FRL of the separating element.
10. Where cable and pipe penetrations reference minimum 75 mm thick AAC or fire rated plasterboard with minimum 2 layers of 13 mm fire rated plasterboard for -/120/120 applications, the performance can be applied to single 13 mm and 16 mm fire rated plasterboard walls. This service needs to incorporate localised thickening in the form of localised build-up with a minimum 100 mm overlap from the aperture using fire rated plasterboard, to both sides of the wall. The FRL of the service will be limited by the FRL of the separating element.

11. Where concrete floor slabs reference FRL -/120/120 outcomes, FRL -/30/30, FRL -/60/60 and FRL -/90/90 are also applicable, provided that, the sealant configuration is maintained and the localised thickness around the services is no less than 150 mm.
12. Where concrete floor slabs reference FRL -/240/240 outcomes, FRL -/30/30, FRL -/60/60, FRL -/90/90, FRL -/120/120 and FRL -/180/180 are also applicable, provided that, the sealant configuration is maintained and the localised thickness around the services is no less than 150 mm.
13. Applicability of FRLs to thinner concrete slabs of a minimum thickness of 120 mm is permissible. The insulation performance of the system will be governed by the concrete slab thickness, as stated in AS/NZS 3600:2018. The overall FRL of the system will be governed by the FRL extracted from AS/NZS 3600:2018.
14. For timber framed walls, no part of the penetration seal may be closer than 100 mm to a stud; the cavity must be closed between the penetration seal and the stud; and a minimum 100 mm of insulation confirmed to be deemed non-combustible in accordance with AS 1530.1:1994 must be provided within the cavity between the penetration seal and the stud.
15. Where the report references 100 mm thick stonewool infill, this can be substituted for 2 × layers of 50 mm thick BOSS Batts or 100 mm thick BOSS FlexiBatt.
16. Wall and floor elements are required to be otherwise tested or assessed by others for the required fire resistance period. In cases where the FRL of the wall or floor is less than that of the penetration, the FRL will be derated accordingly.
17. Test results for cables remain valid if the diameter of a single cable is reduced and/or the number of cables in a bunch is reduced, provided that the overall diameter of the bunch of any individual cable is not greater than that tested.
18. The test results obtained with the standard configuration cover all types of insulated cables with copper or aluminium conductors, fibre optic cables and bundled communication cables, except hollow cables.
19. Results obtained from tests where the supports pass through the seal are applicable to those situations where the support is not continued but not vice versa.
20. The total number of cross sections of services (including insulation) should not exceed 60% of the penetration area. The test results obtained using standard configurations for cable penetration systems are valid for:
 - All types of steel cable trays and ladders.
 - Any cable penetration size equal to or smaller than that tested, provided the total amount of cross sections of the cables (core and insulation) does not exceed 60% of the penetration.
 - Support for services in walls and floors must be maintained as per AS 1530.4:2014 and AS 4072.1:2005 requirements.
21. Results obtained in minimum 235 mm thick ceiling or ceiling-floor systems – as tested in FRT180474 R1.0 – can be applied to ceiling or ceiling-floor systems of greater thickness of the same construction, as tested with 2 layers of 13 mm fire-rated plasterboard on the exposed face.
22. Where specified, services penetrating double layers of 50 mm thick BOSS batts are protected with BOSS FireMastic-HPE sealant installed on both faces. The BOSS batts may be pattress fitted overlapping (minimum 100 mm overlap) the separating element or friction-fitted in the aperture bedded with BOSS FireMastic-HPE sealant. The BOSS batts may be a combination of pattress and friction fitting. For example, one layer of Batt is friction fitted and the other is pattress fitted on one side or both sides of the substrate. The maximum aperture size in walls is 600 mm × 600 mm.
23. If the batts are pattress fitted, they must be fixed using suitable screws, fixings and washers to the substrate with minimum 30 mm embedment at maximum 300 centres or at Batt corners, additionally, the pattress fitted batt must overlap the separating element with minimum 50 mm on all four sides. If friction-fitted and bedded within the aperture, the overall

size of the batts may be made of cut batt sections butt jointed together and fitted after the services are installed. Sealant or ablative coating must be used to bed the cut batts together and to seal the edges of the batt with the separating element and with the service. The BOSS batts must be coated on both faces with an ablative coating. Additionally, each vertical and horizontal cut of the batt must be sealed with BOSS FireMastic-HPE sealant at the interface between the batts and the service and between the batt and the separating element.

24. FRLs assessed in flexible walls and rigid walls are applicable to the same services penetrating a large aperture fitted with two layers of 50 mm thick BOSS Batts friction-fitted or pattress fitted on either side, provided that the Batts have been tested or assessed in this configuration to have the minimum established FRL by an ATL.
25. The HVAC bundle services outlined in the outcome tables represent the maximum number of services, and services are allowed to be removed from the bundle provided the annular gap and depth (and fillet, if applicable) are maintained.
26. Where used, non-fire retardant pipe lagging can be substituted for fire retardant lagging.

Table 3 Separating elements – Walls

Item number	Thickness	Description	Framing thickness	Insulation
1.	144 mm	Minimum two layers of 13 mm thick fire rated plasterboard.	92 mm steel framing	Fletcher Insulation Pink Partition 14 R2.2 or equivalent.
2.	156 mm	Minimum two layers of 13 mm thick fire rated plasterboard on one side and 25 mm shaftliner on the other	102 mm steel framing	Fletcher Insulation Pink Partition 14 R2.2 or equivalent.
3.	130 mm	Minimum two layers of 13 mm thick fire rated plasterboard	75 mm steel framing	-
4.	128 mm	<ul style="list-style-type: none"> • Exposed side - 25 mm thick fire rated shaftliner board • Unexposed side - two layers of minimum 13 mm thick fire rated plasterboard 	102 mm steel framing	75 mm thick Earthwool
5.	116 mm	Both sides - two layers of minimum 13 mm thick fire rated plasterboard	64 mm steel framing	-
6.	100 mm	Both sides - two layers of minimum 12.5 mm thick fire rated plasterboard	50 mm steel framing	50 mm thick mineral wool
7.	90 mm	Both sides - one layer of 13 mm thick Gyproc Fireline plasterboard	64 mm steel framing	-
8.	200 mm	150 mm AAC wall with single 50 mm Fire Batt to the unexposed side	-	-
9.	150 mm	AAC wall	-	-
10.	75 mm	75 mm thick double mesh CSR Hebel	-	-

Item number	Thickness	Description	Framing thickness	Insulation
11.	137mm	CLT wall - The outer lamella thickness must be equal to or greater than 33 mm	-	-
12.	130 mm	CLT wall- The outer lamella thickness must be equal to or greater than 33 mm	-	-

Table 4 Separating elements – floors

Item number	Thickness	Description	Framing	Type
1.	235 mm	Exposed side - two layers of 13 mm thick GIB Fyrelite plasterboard Unexposed side – one layer of 19 mm thick particleboard flooring	MGP10, 190 45 mm timber framing	Ceiling
2.	125 mm	Concrete slab	-	Floor
3.	150 mm	Concrete slab	-	Floor
4.	150 mm	AAC	-	Floor
5.	70-130 mm	Composite floor system of ComFlor 60 deck cast with concrete	-	Floor

4.2 Referenced test data

The assessment of the variation to the tested systems and the determination of the expected performance are based on the results of the fire tests documented in the reports summarised in Table 5. Further details of the tested systems are included in Appendix A.

Table 5 Referenced test data

Report number	Test sponsor	Test date	Testing authority
WF 329129	FSi Limited	16 September 2013	Warringtonfire, UK
EWFA 2891600b.3	Brookfield Multiplex Constructions P/L	25 September 2013	Warringtonfire, Aus
WARRES 334037-A	FSi Limited	25 November 2013	Warringtonfire, UK
WARRES 334037-D	FSi Limited	28 November 2013	Warringtonfire, UK
WARRES 342026 iss2	FSi Limited	5 August 2014	Warringtonfire, UK
WARRES 342025	FSi Limited	23 September 2014	Warringtonfire, UK
FSP 1734	BOSS Fire and Safety Pty Ltd -Australia	9 December 2015	CSIRO
WARRES 359902 FR	FSi Limited	15 December 2015	Warringtonfire, UK
WARRES 359904 Issue 2	FSi Limited	15 December 2015	Warringtonfire, UK
WARRES 371239	FSi Limited	28 September 2016	Warringtonfire, UK
EWFA 54783400.2	Multiplex Australasia	26 April 2018	Warringtonfire, Aus
EWFA55693000.2	BOSS Fire (Australia) Pty Ltd	6 August 2018	Warringtonfire, Aus
CHILT/RF 12089A AR5	BOSS Fire and Safety Pty Ltd -Australia	6 August 2018	Exova Warringtonfire Chiltern House, High Wycombe.

Report number	Test sponsor	Test date	Testing authority
FRT180137.2	BOSS Fire and Safety Pty Ltd -Australia	7 March 2019	Warringtonfire, Aus
FRT180472.1	BOSS Fire and Safety Pty Ltd -Australia	8 March 2019	Warringtonfire, Aus
FRT180473.1	BOSS Fire and Safety Pty Ltd -Australia	12 March 2019	Warringtonfire, Aus
FSP 2073	Knauf Plasterboard Pty Ltd	13 January 2020	CSIRO
FRT 180474.3	BOSS Fire and Safety Pty Ltd -Australia	17 January 2020	Warringtonfire, Aus
FP 10422-002 issue 2	The Insulation Contractors Association of Australia Queensland Inc – c/o B and D Insulation Contracting	22 May 2019	BRANZ
FP 10422-001 issue 2	The Insulation Contractors Association of Australia Queensland Inc – c/o B and D Insulation Contracting	24 May 2019	BRANZ
FSP 2084	Knauf Plasterboard Pty Ltd	12 February 2020	CSIRO
FRT 210330 R1.0	BOSS Products (Australia) Pty Ltd	24 June 2020	Warringtonfire, Aus
FRT 220049 R1.0	BOSS Products (Australia) Pty Ltd	27 June 2020	Warringtonfire, Aus
FSP 2191	BOSS Products (Australia) Pty Ltd	2 January 2021	CSIRO
FRT 210322.1	BOSS Products (Australia) Pty Ltd	18 January 2022	Warringtonfire, Aus
FRT220141 R1.1	BOSS Products (Australia) Pty Ltd	15 July 2022	Warringtonfire, Aus
FSP 1791	BOSS Products (Australia) Pty Ltd	14 March 2017	CSIRO
FSP 1833	BOSS Products (Australia) Pty Ltd	20 June 2017	CSIRO
FSP 2084	Knauf Plasterboard Pty Limited	6 May 2020	CSIRO
FSP 2053	Knauf Plasterboard Pty Limited	23 April 2020	CSIRO

4.3 Variations to the tested systems

The tested systems and variations to those tested systems – together with the referenced standard fire tests – are described in Table 6.

Figure 1 to Figure 10 depict schematic drawings illustrating the construction details for the proposed services. These drawings provide a visual representation of the various generic installations and serve as a helpful reference for understanding fire protection.

Table 6 Variations to tested systems

Reference tests	Description	Variations
<p>All test reports referenced in Table 5.</p>	<p>Various combustible pipe penetrations, insulated metal pipes, cables, cable bundles and HVAC bundles protected with BOSS FireMastic-HPE sealant were tested in accordance with BS EN 1366-3:2009⁶ and AS 1530.4:2014.</p>	<p>It is proposed to assess:</p> <ul style="list-style-type: none"> • The expected fire resistance in accordance with AS 1530.4:2014. • All tested penetrations, including intermediate sizes, were tested to determine their expected FRL across the separating elements as defined in Table 3 and Table 4

⁶ European Committee for Standardization, 2009, Fire resistance tests for service installations. Penetration seals, BS EN 1366-3:2009, European Committee for Standardization, Brussels, Belgium.

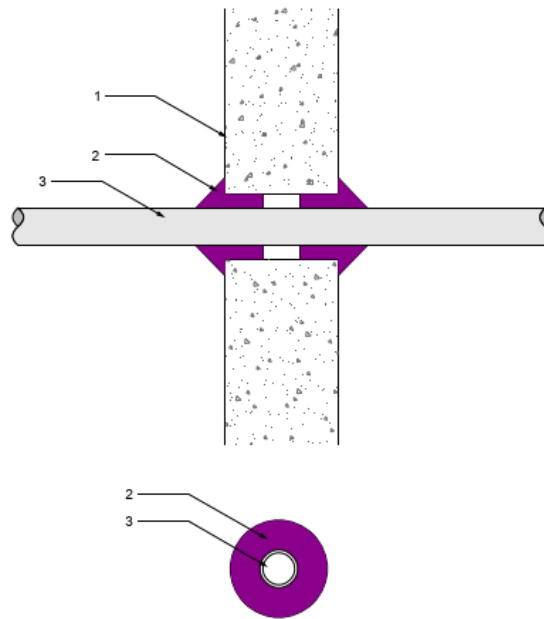

Figure 1 Typical arrangement of combustible pipes in min 75 mm thick rigid walls protected with BOSS FireMastic-HPE finished with a surface fillet. Up to FRL -/120/120 or 120/120/120

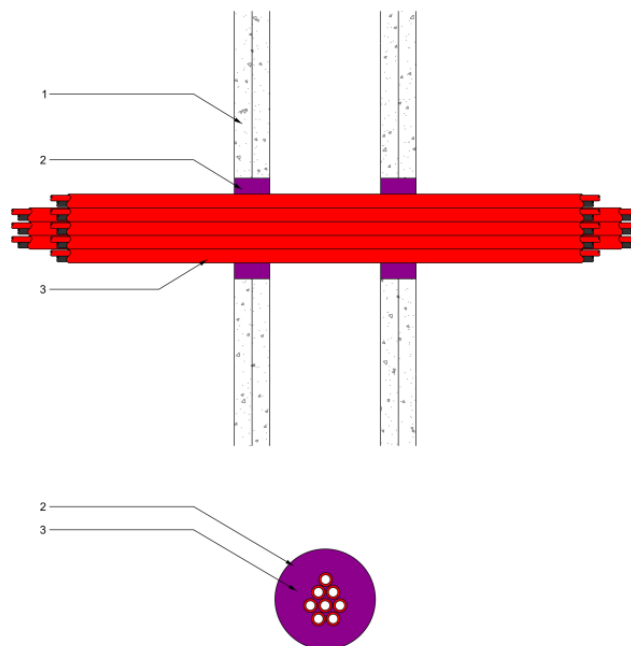

Figure 2 Typical arrangement of cable bundles in min 116 mm thick flexible walls protected with BOSS FireMastic-HPE finished flush with the wall. Up to FRL -/120/120 or 120/120/120. Flexible walls with a lesser FRL must have a minimum single layer 13 mm or 16 mm fire rated plasterboard and localised thickening.

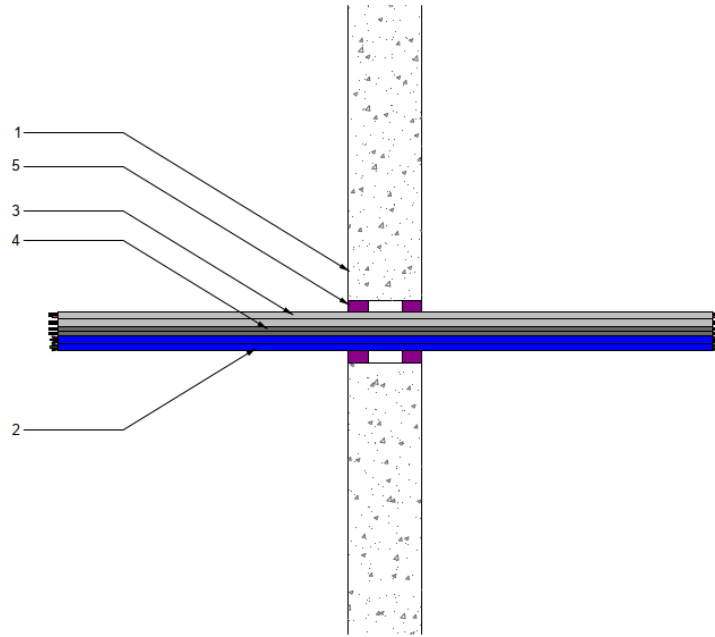

Figure 3 Typical arrangement of cable bundles in min 75 mm thick rigid walls protected with BOSS FireMastic-HPE sealant finished flush with the wall. Up to FRL -/120/120 or 120/120/120

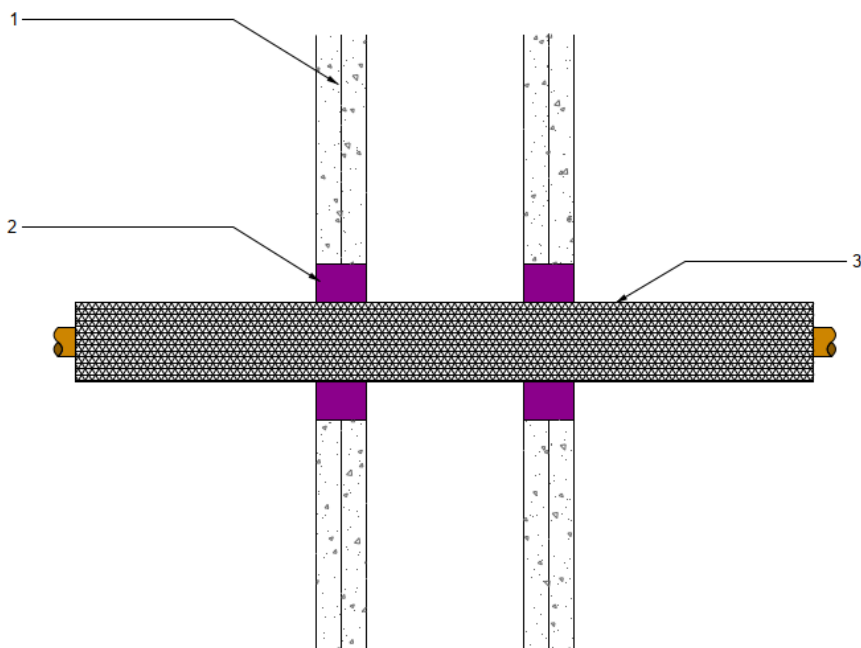

Figure 4 Typical arrangement of insulated metal pipes in min 116 mm thick flexible & rigid walls protected with BOSS FireMastic-HPE finished flush with the wall. FRL up to - /120/120 or 120/120/120. Flexible walls with a lesser FRL must have a minimum single layer 13 mm or 16 mm fire rated plasterboard & localised thickening.

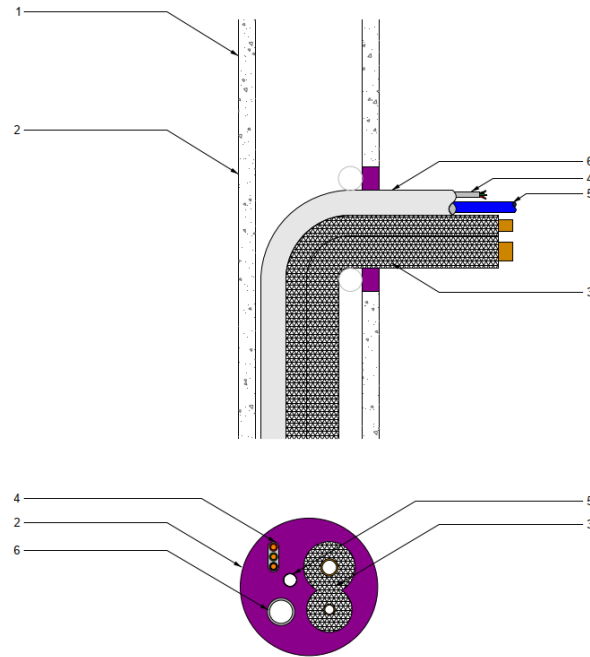

Figure 5 Typical arrangement of one-sided penetration of HVAC services protected with BOSS FireMastic-HPE finished flush with the wall. Applicable to single layer and double layer plasterboard systems and rigid walls. For FRL's relating to -/60/60 minimum wall thickness is 90 mm. For FRL's relating to -/90/90 and -/120/120 minimum wall thickness is 116 mm.

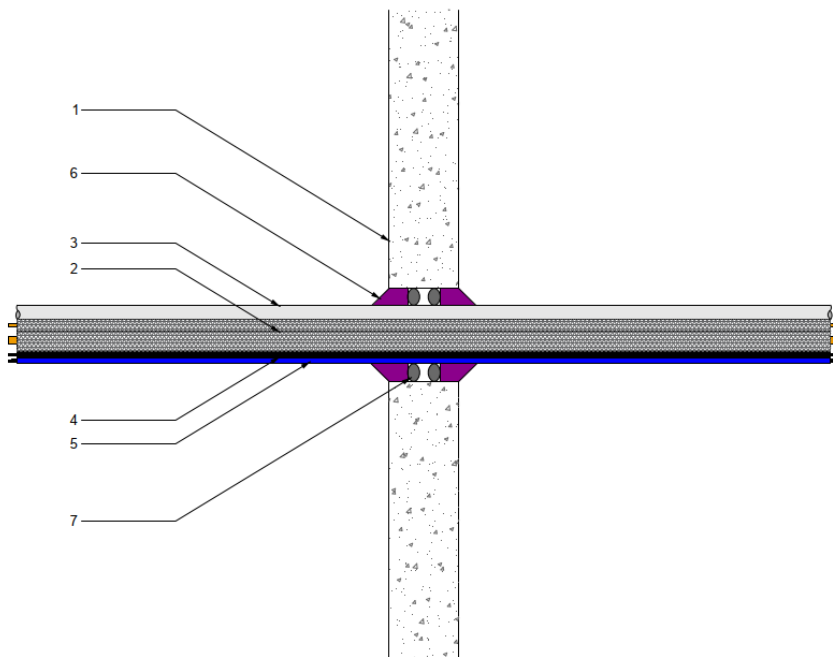

Figure 6 Typical arrangement of HVAC services protected with BOSS FireMastic-HPE finished with a fillet of sealant in minimum 75 mm thick rigid walls. Up to FRL - /120/120 & FRL 120/120/120.

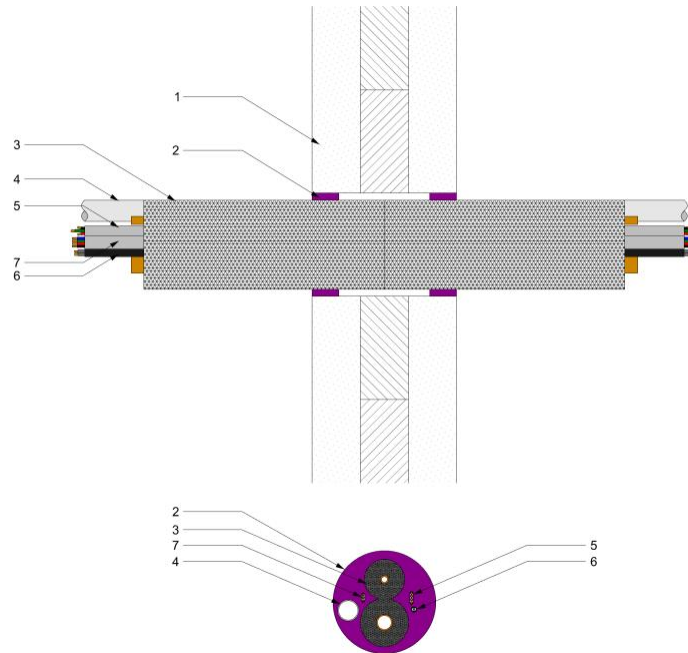

Figure 7 Typical arrangement of HVAC services protected with BOSS FireMastic-HPE sealant finished with a flush seal with minimum 130 mm thick CLT & Rigid walls.

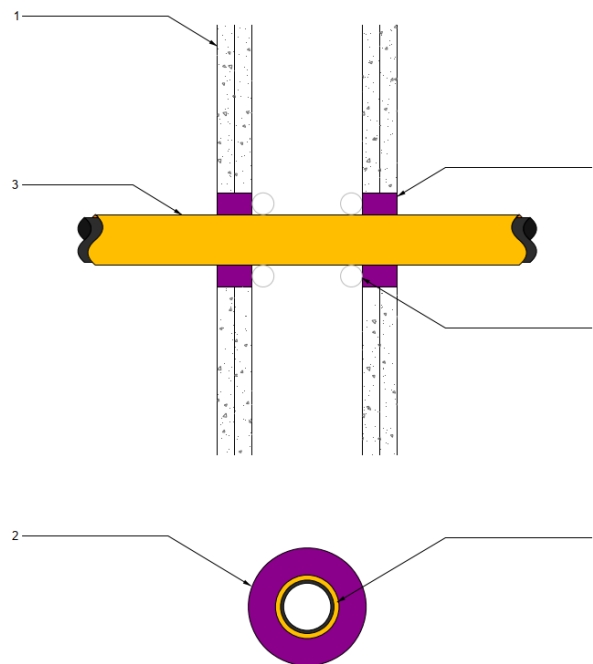

Figure 8 Typical arrangement of combustible pipes protected with BOSS FireMastic-HPE sealant finished with a flush seal in minimum 116 mm thick flexible and rigid walls Up to FRL -/120/120 and 120/120/120.

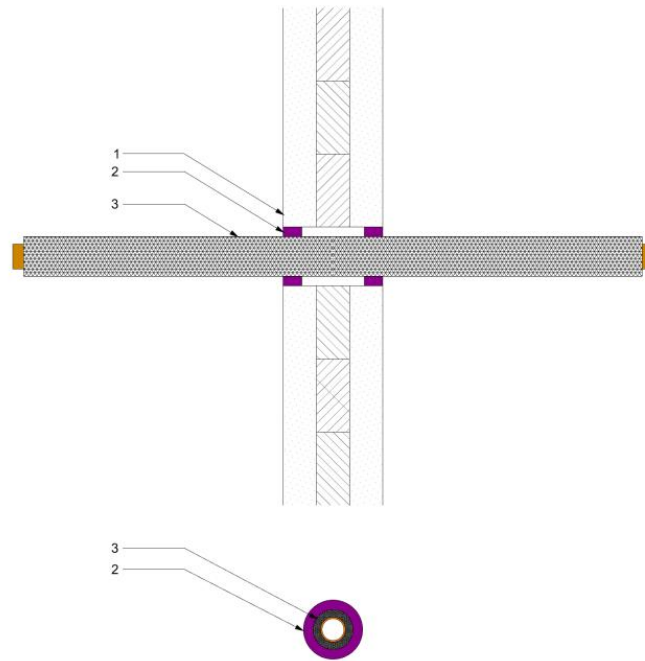

Figure 9 Typical arrangement of insulated pipes protected with BOSS FireMastic-HPE sealant finished flush with the wall in minimum 130 mm thick CLT & rigid walls Up to FRL -/120/120 & 120/120/120.

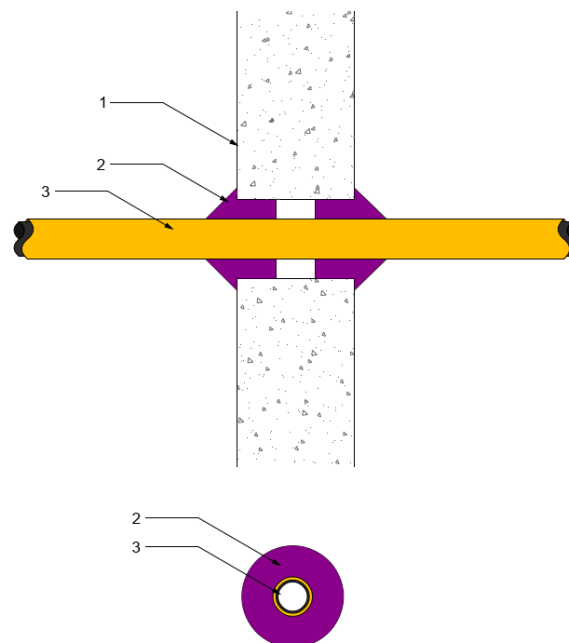

Figure 10 Typical arrangement of combustible pipes protected with FireMastic-HPE sealant finished with a fillet of sealant in minimum 75mm thick AAC & rigid walls Up to FRL -/120/120 and 120/120/120.

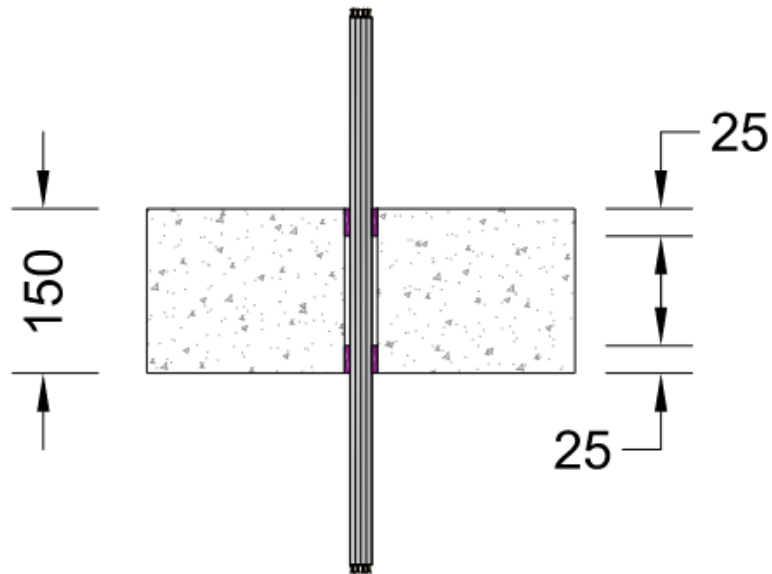

Figure 11 Typical arrangement of cables protected with FireMastic-HPE sealant finished flush with the floor in minimum 150 mm thick concrete slab Up to FRL -/240/240 and 240/240/240.

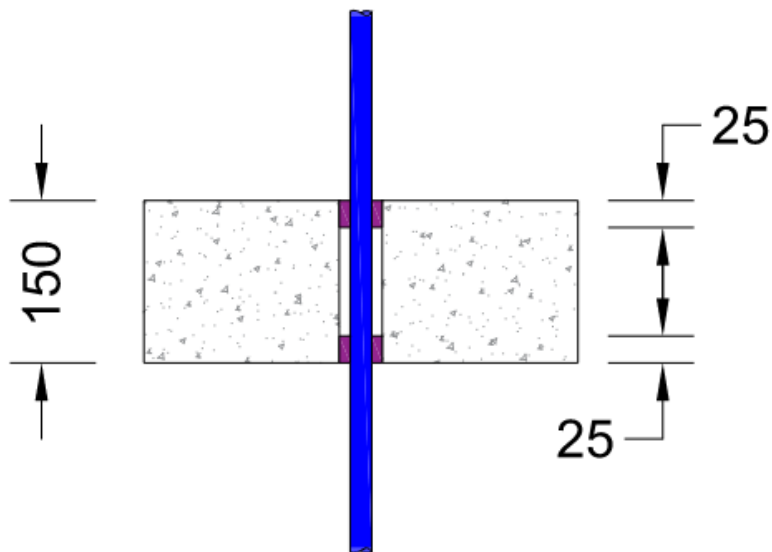

Figure 12 Typical arrangement of combustible pipes protected with FireMastic-HPE sealant finished flush with the floor in minimum 150 mm thick concrete slab Up to FRL -/240/240 and 240/240/240.

5. Relevance of EN 1366-3:2009 test data with respect to AS 1530.4:2014

5.1 Description of variation

The fire resistance tests WARRES 359904, WARRES 342025, ChiltRF12089A, WARRES 334037-D and WARRES 334037-A were conducted in accordance with EN 1366-3:2009⁷ and EN 1363-1:1999⁸. This standard differs from AS 1530.4:2014 and the significance of these differences is discussed below.

5.2 Methodology

The method of assessment used is summarised in Table 7.

Table 7 Method of assessment

Assessment method	
Level of complexity	Intermediate assessment
Type of assessment	Qualitative

5.3 Assessment

5.3.1 Temperature regime

The furnace temperature regime for fire resistance tests conducted in accordance with AS 1530.4:2014 follows the same trend as EN 1363-1:1999.

The parameters outlining the accuracy of control of the furnace temperature in AS 1530.4:2014 and EN 1363-1:1999 are not appreciably different.

5.3.2 Furnace thermocouples

The furnace thermocouples specified in AS 1530.4:2014 are type K, mineral insulated metal sheathed (MIMS), with a stainless-steel sheath having a wire diameter of less than 1.0 mm and an overall diameter of 3 mm. The measuring junction protrudes at least 25 mm from the supporting heat resistant tube.

The furnace thermocouple specified in EN 1363.1:1999 is made from a folded steel plate that faces the furnace chamber. A thermocouple is fixed to the side of the plate facing the specimen, with the thermocouple hot junction protected by a pad of insulating material.

The plate part is to be constructed from 150 ±1 mm long by 100 ±1 mm wide by 0.7 ±0.1 mm thick nickel alloy sheet strips.

The measuring junction is to consist of nickel chromium/nickel aluminium (Type K) wire as defined in IEC 60584-1, contained within mineral insulation in a heat-resisting steel alloy sheath of a nominal diameter of 1 mm, with the hot junctions electrically insulated from the sheath.

The thermocouple hot junction is to be fixed to the geometric centre of the plate by a small steel strip made from the same material as the plate. The steel strip can be welded to the plate – or may be screwed to it – to facilitate replacement of the thermocouple. The strip should be approximately 18 mm by 6 mm if it is spot-welded to the plate, and nominally 25 mm by 6 mm if it is to be screwed to the plate. The screw is to be 2 mm in diameter.

The assembly of plate and thermocouple should be fitted with a pad of inorganic insulation material 97 ±1 mm by 97 ±1 mm by 10 ±1 mm thick with a density of 280 ±30 kg/m³.

⁷ European Committee for Standardization, 2009, Fire resistance tests for service installations. Penetration seals, BS EN 1366-3:2009, European Committee for Standardization, Brussels, Belgium.

⁸ European Committee for Standardization, 1999, Fire resistance tests – General requirements, BS EN 1363-1:1999, European Committee for Standardization, Brussels, Belgium.

The relative locations of the furnace thermocouples for the exposed face of the specimen – for AS 1530.4:2014 and EN 1363-1:1999 – are 100 mm +10 mm and 100 mm +50 mm, respectively.

The furnace control thermocouples required by EN 1363-1:1999 are less responsive than those specified by AS 1530.4:2014. This variation in sensitivity can produce a potentially more onerous heating condition for specimens tested to EN 1363-1:1999, particularly when the furnace temperature is changing quickly in the early stages of the test.

5.3.3 Specimen thermocouples

For penetration sealing systems, thermocouples are fixed in generally similar locations on the unexposed face in accordance with both EN 1363-1:1999 and AS 1530.4:2014.

5.3.4 Furnace pressure

For services penetrating vertical and horizontal separating elements, the furnace pressure conditions are very similar between EN 1366-3:2009 and AS 1530.4:2014.

The parameters outlining the accuracy of control of the furnace pressure in AS 1530.4:2014 and EN 1363-1:1999 are also not appreciably different.

5.3.5 Performance criteria

AS 1530.4:2014 specifies the following performance criteria for building materials and structures:

- structural adequacy (not relevant to the referenced test).
- integrity.
- insulation.

Integrity

The integrity criteria differ slightly between AS 1530.4:2014 and EN 1363.1:1999.

While a specimen maintains its insulation performance, the specimen shall be deemed to have failed the integrity criterion – in accordance with AS 1530.4:2014 – if it collapses or sustains flaming or other conditions on the unexposed face, which ignites the cotton pad when applied for up to 30 seconds.

A penetration specimen shall be deemed to have failed the integrity criterion in accordance with AS 1530.4:2014 when any of the following occurs:

- Sustained flaming for 10 seconds.
- A gap forms that allows the passage of hot gases to the unexposed face and ignites the cotton pad when applied for up to 30 seconds.

Except for minor technical variations, the integrity criteria in EN 1363-1:1999 are generally applied in a comparable manner.

Insulation

The general insulation criteria of AS 1530.4:2014 and EN 1363-1:1999 are not appreciably different.

5.3.6 Specimen configuration

AS 1530.4:2014 specifies for plastic pipes that the external projection away from the furnace shall be a minimum of 2000 mm. The pipes shall be capped on the exposed side and left uncapped on the unexposed side.

EN 1366-3:2009 requires that the pipes extend on the fire side and non-fire side by a minimum of 500 mm. The plastic pipes tested in the referenced tests had both ends uncapped – thus presenting a more onerous case than that prescribed in AS 1530.4:2014.

Plastic pipes tested in the referenced fire resistance tests generally extend 500 mm on exposed and unexposed sides. This variation is addressed in the following section.

With respect to the pipe end configurations, AS 1530.4:2014 stipulates that the services end conditions shall be representative of those intended to be used in practice.

The EN standard stipulates the following field of application based on the tested pipe end configuration:

Table 8 Field of application based on the tested pipe end configuration

		Tested			
		U/U	C/U	U/C	C/C
Covered	U/U	Y	N	N	N
	C/U	Y	Y	N	N
	U/C	Y	Y	Y	N
	C/C	Y	Y	Y	Y
Y=acceptable, N=not acceptable					

Based on the review of the test data and the above field of application, it is the opinion of this testing authority that services tested with an open/open end fire configuration are considered to be the worst-case scenario as the hot gases will have a clear path to the unexposed side. As a result, the thermocouple placed on the service is expected to record the highest temperature when compared to the rest of the pipe end configurations. Therefore, FRL achieved in the U/U configuration can be extended to services tested in any of the pipe end configurations.

With respect to the services tested in an open/closed configuration or closed/closed configuration, it is considered that both configurations are not in line with the general requirements of AS 1530.4:2014. However, clause 10.4.5 of AS 1530.4:2014 stipulates that “service end conditions must be representative of those intended to be used in practice”, therefore, it is reasonable to extend the FRL achieved in both configurations provided that they are representative of the system used in practice.

5.3.7 Application of test data to AS 1530.4:2014

The variation in furnace heating regimes, furnace pressure, furnace thermocouples, and the responses of the different thermocouple types to the furnace conditions are not expected to have an overall significant effect on the outcome of the referenced fire resistance tests.

The plastic pipes tested in the reference tests extended 500 to 550 mm away from the walls and floors on the unexposed side rather than 2000 mm as required by AS 1530.4:2014.

Theoretically, this difference can affect the drawing of hot gases through the pipe by a ‘stack effect’ and can lead to high temperatures on the unexposed side of the specimen when compared to having a shorter pipe extension on the unexposed side.

The impact of the stack effect on the tested services can be significant when there are gaps at the penetrations and hot gasses are passing in the pipes, particularly for floor specimens. The longer the length of pipe above the sealing system, the greater the increase in pressure across the sealant or gap.

However, for each of the assessed plastic pipe services, the referenced test data shows that the BOSS sealing systems completely closed off the softened plastic pipe via the intumescent material such that the temperatures measured on the pipe remained steady or steadily increased without exhibiting any secondary temperature peaks. If the expanded intumescent material fully blocks the pipe aperture on the exposed side or within the aperture, then – irrespective of the length of the pipe on the unexposed side – the service is expected to perform similarly. Based on this rationale, the stack effect is not expected to be significant – even if the plastic pipe length on the unexposed side is 2000 mm. Thus, the difference in service length for plastic pipes between EN 1366-3:2009 and AS 1530.4:2014 is not expected to cause any difference in performance for the assessed services.

For walls, the stack effect is not as significant. In any case, the same rationale applied above applies.

Based on the above discussion, the referenced test data from test reports WARRES 359904, WARRES 342025, ChiltRF12089A, WARRES 334037-D and WARRES 334037-D can be used to support this assessment conducted to AS 1530.4:2014.

6. Assessment 1 – Pipe services protected with BOSS FireMastic–HPE sealant

6.1 Description of variation

It is proposed that combustible and insulated metal pipes penetrating flexible and rigid walls, ceilings and rigid floor constructions are assessed to be protected with BOSS FireMastic-HPE sealant.

In this section, the pipes considered include uPVC, HDPE, PP, PE, PEX-AL-PEX, PEX-A, PEX-B, cPVC, ABS, insulated copper, and insulated steel pipes.

- The vertical separating elements considered in this assessment are given below.
- Minimum 116 mm thick flexible or rigid walls
- Minimum 75 mm thick AAC walls or rigid walls
- Minimum 130 mm thick CLT walls
- Plasterboard walls or rigid walls with double layer of 50 mm thick “BOSS Fire Batt” aperture – Factory applied “BOSS Ablative Coating” to both faces and PS coating to exposed face.
- The horizontal separating elements considered in this assessment are:
- Minimum 235 mm thick ceiling system
- Minimum 150 mm AAC floor
- Minimum 125 mm concrete slab
- ComFlor® 60 – 100 mm thick floor system (Max 130 mm thick / min 70 mm thick)
- Concrete floor with double layer of 50 mm thick “BOSS Fire Batt” aperture – Factory applied “BOSS Ablative Coating” to both faces and PS coating to exposed face.

6.2 Methodology

The method of assessment used is summarised in Table 9.

Table 9 Method of assessment

Assessment method	
Level of complexity	Complex assessment
Type of assessment	Qualitative

6.3 Assessment of various combustible pipes in minimum 116 mm thick flexible wall systems or rigid walls

6.3.1 Proposed constructions

Table 10 lists various combustible pipes tested in FSP 2191, FSP 1734 and EWFA 55693000.2 in accordance with AS 1530.4:2014 and in ChiltRF12089A and WARRES 334037-D in accordance with BS EN 1366-3:2009 and BS EN 1366-4:2009.

In the reference test FSP 2191, a fire resistance test was conducted, which included two plastic pipe penetrations and two BOSS fire transit boxes fitted with or without services, installed in a framed plasterboard wall system. The wall system consisted of two layers of 13 mm thick CSR Fyrchek plasterboard on both sides of 64 mm steel (BMT 0.50 mm) studs with screw fixing at 300 mm centres. The wall system CSR 1078 had an established FRL of -/120/120.

In test EWFA 55693000.2, a fire resistance test was conducted on various pipes and cable services protected with various BOSS penetration protection systems in a 144 mm thick fire rated flexible wall

system. The pipes are proposed to be installed in flexible wall systems and protected with BOSS FireMastic-HPE sealant.

In test FSP 1734, a 116 mm thick steel stud framed wall lined on each side with two layers of 13 mm thick fire rated plasterboards was tested. Seven services penetrated the separating element. All services were protected with BOSS FireMastic-HPE sealant.

In test ChiltRF12089A, a 120 mm thick steel stud/plasterboard clad partition was tested in accordance with BSEN 1366-3. The supporting construction was penetrated with nine service penetrations. The penetrations were sealed with BOSS FireMastic-HPE sealant. In this section, the combustible pipes protected by BOSS FireMastic-HPE sealant are discussed.

In the reference test WARRES 334037-D, a 100 mm thick wall was penetrated with fifteen various combustible and insulated metal services. Services were protected with a sealant identical to BOSS FireMastic-HPE sealant.

Table 10 Tested combustible pipes in flexible wall systems

Services	Reference test	Wall thickness	Nominal pipe diameter (mm)	Annular gap (mm)	Local fire protection	FRL
cPVC	EWFA 49599300.7 FSP1734	116 mm	43 mm	17.5 mm	25 mm deep both sides with backing rod and 15 mm×15 mm fillet on both sides	-/120/120
	EWFA 55693000.2	144 mm	50 mm	20 mm	Depth of plasterboard and finished flush on the wall surface	-/120/60
uPVC	EWFA 49599300.7 FSP1734	116 mm	20 mm	0 mm	15 mm fillet on both sides	-/120/120
	EWFA 55693000.2	144 mm	40 mm	20 mm	Depth of plasterboard and finished flush on both sides	-/120/120
	EWFA 55693000.2	144 mm	50 mm	20 mm	Depth of plasterboard and finished flush on both sides	-/120/120 C/U
	EWFA 55693000.2	144 mm	80 mm	20 mm	Depth of plasterboard and finished flush on both sides	-/90/90
	FSP 2084	118 mm	43 mm	21.5 mm	Depth of plasterboard and finished flush on unexposed face	-/90/90
	FSP 1734	116 mm	25 mm	0 mm	20 mm fillet from both sides	-/120/120
PVC	WF 334037/D	100 mm	40 × 1.9 mm	20 mm	25 mm deep with 10 ×10 mm fillet on both sides	Integrity: 120 min Insulation:120 min

Services	Reference test	Wall thickness	Nominal pipe diameter (mm)	Annular gap (mm)	Local fire protection	FRL
	WF 334037/D	100 mm	125 mm 9.2 mm	20 mm	25 mm deep with 10 ×10 mm fillet on both sides	Integrity: 60 min Insulation:60 min
	WF 334037/D	100 mm	125 mm 1.8 mm	20 mm	25 mm deep with 10 ×10 mm fillet on both sides	Integrity: 30 min Insulation:30 min
	FSP 2073	128 mm	43 mm	23.5 mm	Depth of plasterboard and finished flush on both sides	-/120/120
	ChiltRF12089A	120 mm	125 × 4.8 mm	16 mm	25 mm deep × 16 mm wide on both faces	Integrity: 120 min Insulation:120 min U/C
	ChiltRF12089A	120 mm	40 × 1.9 mm	10 mm	25 mm deep × 16 mm wide on both faces	Integrity: 120 min Insulation:120 min U/C
	ChiltRF12089A	120 mm	40 × 3.0 mm	10 mm	25 mm deep × 16 mm wide on both faces	Integrity: 120 min Insulation:120 min U/C
	ChiltRF12089A	120 mm	125 × 7.4 mm	16 mm	25 mm deep × 16 mm wide on both faces	Integrity: 120 min Insulation:120 min U/C
HDPE	ChiltRF12089A	120 mm	90 mm	12.5 mm	25 mm deep both sides finished flush	Integrity: 120 min Insulation:120 min U/C and C/C
PP	334037/D	100 mm	40 mm	20 mm	25 mm deep with 10 ×10 mm fillet on both sides	Integrity: 120 min Insulation:120 min U/C and C/C
PE	334037/D	100 mm	40 mm 3.7 mm	20 mm	25 mm deep with 10 ×10 mm fillet on both sides	Integrity: 30 min Insulation:30 min
ABS	ChiltRF12089A	120 mm	90 mm	12.5 mm	25 mm deep both sides finished flush	-/120/120 U/C and C/C
	334037/D	100 mm	40 mm	20 mm	25 mm deep with 10x10 mm fillet on both sides	-/120/120

Services	Reference test	Wall thickness	Nominal pipe diameter (mm)	Annular gap (mm)	Local fire protection	FRL
PEX/AL/PEX	FSP 2191	116 mm	20 mm	5 mm	Depth of plasterboard and finished flush on both sides	-/120/120
	EWFA 55693000.2	144 mm	25 mm	20 mm	Depth of plasterboard and finished flush on both sides	-/120/30
	FSP 1734	116 mm	20 mm	20 mm	25 mm deep on both sides and finished flush with the wall	-/120/120
PE-Xb	EWFA 55693000.2	144 mm	25 mm	20 mm	Depth of plasterboard and finished flush on both sides	-/120/120
	EWFA 55693000.2		25 mm	3.5 mm	25 mm deep to fill the gap between the collar and the pipe on both exposed and unexposed side.	-/120/60
	EWFA 55693000.2		32 mm	20 mm	Depth of plasterboard and finished flush on both sides	-/120/0
	FRT220141	116	Up to 25 mm	10 mm	Depth of plasterboard and finished flush on both sides as shown in Figure 8	-/120/120
	FRT220141		Up to 20 mm	20 mm	Depth of plasterboard and finished with a 20 mm × 20 mm fillet on both sides.	-/120/120
PEX-A (one sided penetration)	FSP 2073	128 mm shaftliner wall 1×25 mm shaftliner from one side and 2×13 mm on the other.	20 mm	17.5 mm	Depth of plasterboard and finished flush on the exposed side	-/120/120

Services	Reference test	Wall thickness	Nominal pipe diameter (mm)	Annular gap (mm)	Local fire protection	FRL
	FSP 2084	118 mm	20 mm	17.5 mm	Depth of plasterboard and finished flush on the unexposed face only as shown in Figure 5	-/90/90
	FSP 2053	118 mm with a baffle made of 13 mm fire rated plasterboard on either side of the wall, in addition to 12 mm plywood fixed to steel angles inside the cavity on the unexposed side.	20 mm	17.5 mm	Depth of plasterboard (26 mm) and finished flush on the exposed side	-/90/90
	FSP 2054	128 mm	20 mm	17.5 mm	Depth of plasterboard (26 mm) and finished flush on the unexposed side	-/120/120
PVC (one sided penetration)	WF 334037/D	100 mm	40 × 1.9 mm	20 mm	25 mm deep with 10 × 10 mm fillet on both sides	-/120/120
	FSP 2084 - Specimen 2	118 mm with a baffle made of 13 mm fire rated plasterboard on either side of the wall inside the cavity	43 mm	22.5 mm	Depth of plasterboard (26 mm) and finished flush on the exposed side	-/90/90

Services	Reference test	Wall thickness	Nominal pipe diameter (mm)	Annular gap (mm)	Local fire protection	FRL
	FSP 2053 - Specimen 2	118 mm with a baffle made of 13 mm fire rated plasterboard on either side of the wall, in addition to 12 mm plywood fixed to steel angles inside the cavity on the unexposed side.	43 mm	23.5 mm	26 mm deep and finished flush with the wall	-/90/90
	FSP 2073 - Specimen 2	128 mm shaftliner wall 1×25 mm shaftliner from one side and 2×13 mm on the other.	43 mm	23.5 mm	Depth of plasterboard (26 mm) and finished flush on the exposed side	-/120/120
	FSP 2054	128 mm	43 mm	6 mm	26 mm deep and finished flush with the wall	-/120/120
PEX	FSP 1791 - Specimen 7	90 mm	20 mm	20 mm	Sealant is used to fill the void between the pipe and the plasterboard, creating an annular gap of 20 mm with a depth of 13 mm. It is then finished flush with the surface of the plasterboard wall on both sides.	-/60/60

Services	Reference test	Wall thickness	Nominal pipe diameter (mm)	Annular gap (mm)	Local fire protection	FRL
	FSP 1833 - Specimen 1	96 mm	20 mm	20 mm	Sealant is used to fill the void between the pipe and the plasterboard, creating an annular gap of 20 mm with a depth of 16 mm. It is then finished flush with the surface of the plasterboard wall on both sides.	-/90/90
	FSP1734	116 mm	20 mm (Positioned off centre)	20 mm	25 mm deep on both sides and finished flush with the wall	-/120/120
	FSP 2191	116 mm	20 mm	5 mm	26 mm deep and finished flush on both sides of the wall	-/120/120
3-piece hand basin tap set	FSP 2073 – Specimen 3	128 mm shaftliner wall 1×25 mm shaftliner from one side and 2×13 mm on the other.	Two PEX-a rehau Rautitan pipes of diameter 25 mm and thickness of 4 mm were running in the wall cavity	17.5 mm	The three faucets annular gaps were sealed with FireMastic-HPE to a depth of 26 mm and finished flush with the wall.	-/120/120
	FSP 2084 – Specimen 3	128 mm shaftliner wall 1×25 mm shaftliner from one side and 2×13 mm on the other.	Two PEX-a rehau Rautitan pipes of diameter 25 mm and thickness of 4 mm were running in the wall cavity	17 mm	The three faucets annular gaps were sealed with FireMastic-HPE to a depth of 26 mm and finished flush with the wall.	-/90/90

6.3.2 Discussion

Improvement of insulation performance

Based on available test evidence, most services achieved a fire resistance performance of -/120/120. However, some services failed insulation performance. This section will discuss the failed systems and the improvements needed to achieve an FRL of -/120/120.

In test EWFA 55693000.2, service 4, a 50 mm diameter cPVC pipe was tested in a 144 mm thick plasterboard wall. BOSS FireMastic-HPE sealant was applied to a depth of 26 mm and finished flush

on the wall from both sides. The system achieved an FRL of -/120/60 as the thermocouple on the pipe, 25 mm away from the sealant recorded a temperature of 194 C°. By observing the temperature-time graph of the test, the temperature – recorded by the thermocouple that was positioned on the pipe 25 mm away from the sealant – increased from the ambient temperature to approx. 150 C° in the first 20 minutes of the test. After 20 minutes, the temperature increases slowly, which indicates that the BOSS FireMastic-HPE sealant expanded and closed off the gaps formed at the interface between the sealant and the melted pipe.

At 65 minutes, the temperature increased to 194 C° and reached approx. 400 C° at 78 minutes. This steep increase is expected to be due to the nature of the sealant material, which becomes more fluid at higher temperatures and loses its viscosity and adhesion to the substrate and the pipe.

Consequently, it is expected that a gap was not closed off at the interface between the sealant and the pipe which allowed the passage of hot gases. FSP 1735, a 43 mm diameter cPVC pipe was tested in 116 mm thick plasterboard, the annular gap was 18.5 mm. The pipe was sealed with BOSS FireMastic-HPE sealant to a nominal depth of 25 mm on both sides, controlled by a backing rod and finished with 15 mm 15 mm fillet on both sides. The system achieved -/120/120. Hence, it is proposed to apply the sealant to depth of 26 mm and add 20 mm 20 mm fillet on both sides to improve the insulation performance for up to 120 minutes.

In test EWFA 55693000.2, specimen 1, a 25 mm diameter PEX/AL/PEX pipe was tested in a 144 mm thick plasterboard wall system. BOSS FireMastic-HPE sealant was applied to the depth of 26 mm and finished flush on the wall from both sides. The thermocouple on the pipe, 25 mm away from the mastic, recorded a temperature of 194 C° at 47 minutes. The thermocouple recorded a rapid increase in temperature in the first 10 minutes to approx. 130 C° then the temperature decreased to below 100 C° as a result of the sealant expansion and closing off the gaps created when the pipe softened and started to melt.

At 45 minutes, the temperature started to rise and reached 450 C° at 120 minutes. When the moisture content in the sealant was driven out due to exposure to high temperatures, the polymer chain within the sealant tended to pack together and solidify, or a chemical reaction might have occurred and created new rigid bonds between the polymer chain. This solid state of the sealant conducts heat to the unexposed side and that was reflected in the uniform increase of temperature with time. In test FSP 2191, a 20 mm diameter pipe was installed in a 30 mm aperture within a 116 mm thick plasterboard wall system and sealed with BOSS FireMastic-HPE sealant to nominal depth of 26 mm on both sides and finished flush. This configuration achieved an FRL of -/120/120. Hence, it is suggested to reduce the annular gap to 11.5 mm to improve the insulation performance of the system.

In test FSP 2191, the tested 20 mm diameter PEX/AL/PEX installed within a 30 mm aperture diameter and sealed with BOSS FireMastic-HPE sealant to a depth of 26 mm on both sides achieved an FRL of -/120/120. The tested pipe contains aluminium reinforcement between the inner and outer layers which is expected to conduct more heat to the unexposed side. Given that PEX-A and PEX-B pipes do not have metal components, the outcome of this test can be extended to cover PEX-A and PEX-B pipes with diameters up to 20 mm, provided the annular gap is kept as tested.

Assessment of intermediate pipe sizes

The outcomes of tests FSP 2191, FSP 1734 and EWFA 55693000.2 are applicable to tested sizes of the combustible pipes, aperture, and annular gap. It is proposed to assess the intermediate pipe sizes up to 120 minutes based on the test results and propose improvements to the system construction to maintain integrity and insulation performance up to 120 minutes. Based on the discussion in the previous section, Table 11 summarises the outcomes of the assessment of combustible pipes installed in flexible wall systems and protected with BOSS FireMastic-HPE sealant.

Requirements for flexible wall systems

In light of the above discussion, flexible walls must have a minimum thickness as tested, and the construction of the wall shall consist of steel studs lined on both faces with two layers of fire rated plasterboard. Unless otherwise specified, the cavity of flexible walls must be filled with R2.0 Glasswool Batt insulation. For services tested in walls with two layers of 13 mm thick plasterboard on both faces, single layer walls are permitted provided that the area around the penetration is built up with an additional layer of fire rated plasterboard, the additional layer must extend at least 100 mm in every direction from the edge of the aperture.

For all cases, the wall must have been tested or assessed by an accredited testing laboratory (ATL) to achieve the required FRL in accordance with AS 1530.4:2014.

Performance of service through rigid walls

In tests, FSP 2191, FSP 1734 and EWFA 55693000.2, the combustible pipes were installed in flexible wall systems and protected with BOSS FireMastic-HPE sealant. FRLs assessed for flexible walls can be applied to the same services penetrating through rigid walls, having the same or greater thicknesses, as applicable, with an established FRL as required as tested or assessed by an ATL.

For all cases, the wall must have been tested or assessed by an accredited testing laboratory (ATL) to achieve the required FRL in accordance with AS 1530.4:2014.

Assessment of separating element with one side penetration

In tests FSP 2084, a 20 mm diameter PEX-A pipe was tested in 118 mm thick plasterboard wall system. The pipe was fitted in a 55 mm diameter aperture and the annular gap was 17.5 mm. The annular gap was filled with BOSS FireMastic-HPE sealant to the full depth of the plasterboard wall and finished flush on both sides. PVC pipe was tested in 120 mm thick plasterboard wall system. The pipe was penetrating the wall from both sides and the 10 mm annular gap was filled with BOSS FireMastic-HPE sealant to the full depth of the plasterboard and finished flush with the wall. The service achieved an FRL of -/120/120. The tested PVC pipe configuration was U/C. It is expected that the separating element with one side penetration is less onerous as the exposed side does not have aperture that might affect its fire resistance level. Hence, the PVC pipe is positively assessed if installed in a flexible wall with one side penetration.

6.3.3 Conclusion

The technical review found that the combustible pipes protected by BOSS FireMastic HPE sealant are capable to achieve the fire resistance levels (FRL) given in Table 11 in accordance with AS 1530.4:2014 and assessed in accordance with AS 4072.1:2005.

Table 11 Assessment outcome of combustible pipes or conduit installed in flexible and rigid wall systems

Services	Minimum wall thickness	Nominal pipe diameter (mm)	Annular gap (mm)	Local fire protection	FRL
cPVC	116 mm	Up to 32 mm (43 mm OD)	18.5 mm	25 mm deep both sides with backing rod and 15 mm×15 mm fillet on both sides	-/120/120
	144 mm	Up to 50 mm (60.3 mm OD)	20 mm	Depth of plasterboard and finished flush on the wall surface	-/120/60
uPVC	116 mm	Up to 20 mm	0 mm	15 mm fillet on both sides	-/120/120
	116 mm	Up to 20 mm	20 mm	Depth of plasterboard and finished with a 20 mm × 20 mm fillet on both sides.	-/120/120
	116 mm	Up to 25 mm	0 mm	20 mm fillet on both sides of the wall	-/120/120
	116 mm	Up to 32 mm	20 mm	Depth of plasterboard and finished with 20 mm × 20 mm fillet on both sides.	-/120/120
	144 mm	Up to 40 mm	20 mm	Depth of plasterboard and finished flush on both sides	-/120/120

Services	Minimum wall thickness	Nominal pipe diameter (mm)	Annular gap (mm)	Local fire protection	FRL
	144 mm	Up to 50 mm	20 mm	Depth of plasterboard and finished flush on both sides	-/120/120 C/U
	144 mm	Up to 80 mm	20 mm	Depth of plasterboard and finished flush on both sides	-/90/90
	118 mm	Up to 43 mm	21.5 mm	Depth of plasterboard and finished flush on unexposed face	-/90/90
PVC	100 mm	Up to 40 × 1.9 mm	20 mm	25 mm deep with 10 × 10 mm fillet on both sides	-/120/120
	100 mm	Up to 125 mm 9.2 mm	20 mm	25 mm deep with 10 × 10 mm fillet on both sides	-/60/60
	100 mm	Up to 125 mm 1.8 mm	20 mm	25 mm deep with 10 × 10 mm fillet on both sides	-/30/30
	128 mm	Up to 43 mm	23.5 mm	Depth of plasterboard and finished flush on both sides	-/120/120
	120 mm	Up to 125 × 4.8 mm	16 mm	25 mm deep × 16 mm wide on both faces	-/120/120 U/C and C/C
	120 mm	Up to 40 × 1.9 mm	10 mm	25 mm deep × 16 mm wide on both faces	-/120/120 U/C
	120 mm	Up to 40 × 3.0 mm	10 mm	25 mm deep × 16 mm wide on both faces	-/120/120 U/C
	120 mm	Up to 125 × 7.4	16 mm	25 mm deep × 16 mm wide on both faces	-/120/120 U/C and C/C
HDPE	120 mm	Up to 90 mm	12.5 mm	25 mm deep both sides finished flush	-/120/120 U/C and C/C
PP	100 mm	Up to 40 mm	20 mm	25 mm deep with 10 × 10 mm fillet on both sides	-/120/120 U/C and C/C
PE	100 mm	40 mm 3.7 mm	20 mm	25 mm deep with 10 × 10 mm fillet on both sides	-/30/30
ABS	120 mm	Up to 90 mm	12.5 mm	25 mm deep both sides finished flush	-/120/120 U/C and C/C
	100 mm	Up to 40 mm	20 mm	25 mm deep with 10x10 mm fillet on both sides	-/120/120
PEX/AL/PEX	116 mm	Up to 20 mm (can be installed off centre as in FSP2191 specimen D)	5 mm-20 mm	Depth of plasterboard and finished flush on both sides	-/120/120
	116 mm	Up to 25 mm	11.5 mm	Depth of plasterboard and finished with a 20 mm × 20 mm fillet on both sides.	-/120/120
	144 mm	Up to 25 mm	Up to 20 mm	Depth of plasterboard and finished flush on both sides	-/120/30

Services	Minimum wall thickness	Nominal pipe diameter (mm)	Annular gap (mm)	Local fire protection	FRL
PE-Xb	144 mm	Up to 25 mm	20 mm	Depth of plasterboard and finished flush on both sides	-/120/120
		Up to 25 mm	3.5 mm	25 mm deep to fill the gap between the collar and the pipe on both exposed and unexposed side.	-/120/60
		Up to 32 mm	20 mm	Depth of plasterboard and finished flush on both sides	-/120/0
	116 mm	Up to 25 mm	10 mm	Depth of plasterboard and finished flush on both sides as shown in Figure 8	-/120/120
		Up to 20 mm	20 mm	Depth of plasterboard and finished with a 20 mm x 20 mm fillet on both sides.	-/120/120
PE-Xa	116 mm	Up to 25 mm	10 mm	Depth of plasterboard and finished flush on both sides as shown in Figure 8	-/120/120
		Up to 20 mm	20 mm	Depth of plasterboard and finished with a 20 mm x 20 mm fillet on both sides.	-/120/120
PEX-A (one sided penetration)	128 mm shaftliner wall 1x25 mm shaftliner from one side and 2x13 mm on the other.	Up to 20 mm	17.5 mm	Depth of plasterboard and finished flush on both sides	-/120/120
	118 mm	Up to 20 mm	17.5 mm	Depth of plasterboard and finished flush on the unexposed face only as shown in Figure 5	-/90/90
	118 mm with a baffle made of 13 mm fire rated plasterboard on either side of the wall, in addition to 12 mm plywood fixed to steel angles inside the cavity on the unexposed side.	Up to 20 mm	17.5 mm	Depth of plasterboard (26 mm) and finished flush on the exposed side	-/60/60

Services	Minimum wall thickness	Nominal pipe diameter (mm)	Annular gap (mm)	Local fire protection	FRL
	128 mm	Up to 20 mm	17.5 mm	Depth of plasterboard (26 mm) and finished flush on the unexposed side	-/120/120
PVC (one sided penetration)	100 mm	Up to 40 × 1.9 mm	20 mm	25 mm deep with 10 × 10 mm fillet on both sides	-/120/120
	118 mm with a baffle made of 13 mm fire rated plasterboard on either side of the wall inside the cavity	43 mm	22.5 mm	Depth of plasterboard (26 mm) and finished flush on the exposed side	-/90/90
	156 mm with a baffle made of 13 mm fire rated plasterboard on the opposite side of the penetration, in addition to 12 mm plywood fixed to steel angles inside the cavity	43 mm	23.5 mm	Depth of plasterboard (26 mm) and finished flush on the exposed side	-/120/120
	128 mm	43 mm	6 mm	Depth of plasterboard (26 mm) and finished flush on the unexposed side	-/120/120
PEX	90 mm	Up to 20 mm	20 mm	Sealant is used to fill the void between the pipe and the plasterboard, creating an annular gap of 20 mm with a depth of 13 mm. It is then finished flush with the surface of the plasterboard wall on both sides.	-/60/60
	96 mm	Up to 20 mm	20 mm	Sealant is used to fill the void between the pipe and the plasterboard, creating an annular gap of 20 mm with a depth of 16 mm. It is then finished flush with the surface of the plasterboard wall on both sides.	-/90/90
	116 mm	Up to 20 mm (Can be installed off centre)	20 mm	25 mm deep and finished flush on both sides with the face of the wall	-/120/120

6.4 Assessment of various combustible pipes in minimum 75 mm thick rigid wall systems

6.4.1 Proposed construction

Table 12 lists the pipes tested in FRT210322.1, FRT220141 R1.1, FRT180473.1. in accordance with AS 1530.4:2014.

In test FRT210322.1, the tested system included 75 mm thick AAC wall system penetrated with 18 services protected with BOSS FireMastic-HPE sealant.

In test FRT220141 R1.1, the tested system included 75 mm thick AAC wall system penetrated with 9 services. The tested combustible pipes were protected with BOSS FireMastic-HPE sealant.

In test FRT180473.1, the tested system included 75 mm thick Hebel Power Panel penetrated with 13 services. The tested combustible pipes covered in this report were protected with BOSS FireMastic-HPE sealant only.

Table 12 Tested combustible pipes in rigid wall systems

Services	Reference test	Wall thickness	Nominal pipe diameter (mm)	Annular gap (mm)	Sealant configuration	FRL
PEX-A	FRT210322.1	75 mm AAC wall	20 mm	20 mm	20 mm deep both sides of the wall	-/120/120
	FRT220141		25 mm	11.5 mm	25 mm deep both sides with 20 × 20 mm fillet both sides as shown in Figure 10	-/120/120
	FRT180473.1		32 mm	14 mm	25 mm deep both sides finished flush	-/120/0
PEX/AL/PEX	FRT210322.1		20 mm	20 mm	25 mm deep both sides finished flush	-/120/60
	FRT220141		20 mm	5 mm	25 mm deep both sides finished flush	-/120/120
	FRT220141		20 mm	10 mm	25 mm deep both sides 20×20 mm fillet both sides as shown in Figure 10	-/120/120
	FRT220141		25 mm	11.5 mm	20 mm deep both sides 20×20 mm fillet both sides as shown in Figure 10	-/120/120
PEX-B	FRT210322.1		20 mm	20 mm	25 mm deep both sides finished flush or 20 mm deep both sides 20×20 mm fillet both sides as shown in Figure 10	-/120/120
	FRT220141		25 mm	11.5 mm	25 mm depth both sides with 20×20 mm fillet on both sides as shown in Figure 10	-/120/120
cPVC	FRT210322.1		32 mm	25.5 mm	20 mm deep with 20 mm fillet on both sides as shown in Figure 1	-/120/90

Services	Reference test	Wall thickness	Nominal pipe diameter (mm)	Annular gap (mm)	Sealant configuration	FRL
UPVC	FRT210322.1		20 mm	2 mm	Surface seal only	-/120/120
	FRT220141		25 mm	7.5 mm	25 mm deep with 20×20 mm fillet on both sides as shown in Figure 1	-/120/120
	FRT210322.1		32 mm	2 mm	20 mm deep with 20×20 mm fillet on both sides as shown in Figure 1	-/120/60
	FRT210322.1		32 mm	20.5 mm	20 mm deep with 15×15 mm fillet on both sides as shown in Figure 1	-/120/120
	FRT180473.1		40 mm	2 mm	10 mm deep with 25×25 mm fillet on both sides as shown in Figure 1	-/120/90

6.4.2 Discussion

Improvements of insulation performance

Based on Table 12, most of the tested services achieved an FRL of -/120/120. However, some services failed to perform up to 120 minutes of integrity and insulation. The failed services and the required improvement to the construction to achieve an FRL of -/120/120 will be discussed in this section.

In test FRT180473.1, specimen L, a 32 mm PEX-A pipe was tested in a 75 mm thick AAC. The pipe was installed in a 70 mm diameter aperture. BOSS FireMastic-HPE sealant was applied to a depth of 25 mm with backing rod support and finished flush on both the exposed and the unexposed sides. The system achieved a FRL of -/120/0. At 13 minutes, the thermocouple positioned on the top of the PEX pipe, 25 mm away from the separating element, recorded a temperature of 201 C°. By observing the temperature-time curve, the temperature increased rapidly in the first 15 minutes and reached approx. 210 C°. After that, the temperature decreased to below 100 C° which indicates that the sealant expanded and closed off the gaps. It is expected that due to the large aperture size, the sealant took longer to close the gaps formed when the pipes softened and melted. Therefore, it is suggested to install the pipe in a 60 mm diameter aperture rather than 70 mm and for more confidence, it is suggested to add a 20 mm ×20 mm sealant fillet on both sides to improve the performance up to 120 minutes.

In test FRT210322.1, service E, a 20 mm diameter PEX/AL/PEX pipe was tested in a 75 mm thick Hebel wall. BOSS FireMastic-HPE sealant was applied to a depth of 25 mm with backing rod support and finished flush on both the exposed and the unexposed sides. At 84 minutes, the system failed insulation. The thermocouple on the PEX/AL/PEX pipe, 25 mm away from the sealant, recorded a temperature of 207 C°. PEX/AL/PEX contains aluminium reinforcement between the inner and outer layers which is expected to conduct more heat to the unexposed side. As discussed above, in the first 10-15 minutes the recorded temperature reached 150C° which indicates that the melting rate of the pipe is higher than the expansion rate of the sealant. This is supported by the reduction of temperature to below 100 C° which means that the sealant closed off the gaps formed when the pipe started to melt. After 15 minutes, it is expected that the sealant moisture will have been driven out and solidified and started to conduct heat in a more uniform manner to the unexposed side. It is recommended to add a 20 mm × 20 mm cone of sealant, which will restrict the passage of the hot gases and move the thermocouple 25 mm further from the aperture, which is expected to improve the system performance to 120 minutes.

In test FRT210322.1, service Q, a 32 mm diameter cPVC pipe was installed in an 83 mm diameter aperture in a Hebel wall. BOSS FireMastic-HPE sealant was applied to a depth of 20 mm with PE

backing rod support and finished with a 15 mm × 15 mm fillet on both the exposed and unexposed sides of the separating element. At 114 minutes, the pipe failed insulation. The thermocouple positioned on the Hebel wall 25 mm from the aperture recorded a temperature of 205 C°. By analysing the temperature data of the failed thermocouple throughout the test, it can be seen that, the temperature increased gradually as a result of the whole specimen is getting heated up. However, after 75 minutes the heat around this thermocouple started to increase in a higher rate compared to other thermocouples surrounding the specimen. This was attributed to a small gap at the interface between the sealant and the separating element, which allowed the passage of hot gases. It is recommended to increase the fillet depth to improve the system's performance for up to 120 minutes.

In test FRT210322.1, service H, a 32 mm diameter UPVC conduit was installed in a 36 mm diameter aperture within a Hebel wall. The service was protected by BOSS FireMastic – HPE sealant in the annular gap between the services and the separating element to a depth of 20 mm with PE backing rod support and finished with a 20 mm × 20 mm fillet on both the exposed and unexposed sides of the separating elements. At 86 minutes, the system failed insulation when the thermocouple positioned on the pipe, 25 mm away from the sealant recorded a temperature of 205 C°. It is expected that the pressure exerted by the amount of sealant filled in the 2 mm annular gap is not sufficient to keep the gaps sealed for the duration of the test. The temperature curve showed that the temperature increment stabilised after 15 minutes to 85 minutes which indicates that the sealant closed off the gaps formed by the melted pipe. However, the temperature increased from approx. 140 C° to 330 C° in 5 minutes which indicates failure of the sealant to keep the gaps closed. Therefore, it is proposed to increase the sealant fillet to 25 mm × 25 mm to improve the system performance to 120 minutes.

In test FRT180473.1, service E, a 40 mm diameter UPVC pipe was tested in a 75 mm thick AAC wall system. The annular gap between the service and the separating element was filled with BOSS FireMastic – HPE to a depth of 10 mm and finished with 25 mm × 25 mm fillet on both the exposed and unexposed side. At 113 mm minutes, the thermocouple on the separating element, 25 mm away from the top of the sealant fillet recorded a temperature of 200 C°. For pipe sizes of 30 mm to 40 mm with 2 mm annular gap, it is suggested to build up with at least 13 mm thick fire rated plasterboard to improve the system performance up to 120 minutes.

Requirements for rigid wall systems

In light of the above discussion, rigid walls must be minimum 75 mm thick and must be AAC, concrete or solid masonry. Thinner rigid walls must be built up on either one or both sides to achieve the minimum thickness required as assessed for the required FRL. The build-up could be fire-rated plasterboard, calcium silicate board, MGO board or BOSS batts and must extend at least 100 mm on all directions from the aperture.

FRLs assessed for AAC blockwork walls, Hebel walls, and Speedpanel walls can be applied to the same services penetrating through rigid walls, having the same or greater thickness, as applicable, (including concrete, solid masonry, Speedpanel, Hebel and Korok) with an established FRL as required as tested or assessed by an ATL. For all cases, the wall must have been tested or assessed by an accredited testing laboratory (ATL) to achieve the required FRL in accordance with AS 1530.4:2014. FRLs assessed in flexible walls and rigid walls are also applicable to the same services penetrating a large aperture fitted with two layers of 50 mm thick BOSS Batts friction-fitted or pattress fitted on either side provided that the Batts have been tested or assessed in this configuration to have the minimum established FRL by an ATL.

6.4.3 Conclusion

The technical review found that the combustible pipes protected by BOSS FireMastic HPE sealant are expected to achieve the fire resistance levels (FRL) given in Table 13 in accordance with AS 1530.4:2014 and assessed in accordance with AS 4072.1:2005.

Table 13 Assessment outcome of combustible pipes in rigid wall systems

Pipe	Wall thickness (mm)	Nominal pipe diameter (mm)	Maximum aperture (mm)	Annular gap (mm)	Sealant configuration	FRL
PE-Xa	75 mm AAC wall	Up to 20	60	20 mm	20 mm deep both sides finished flush with the wall	-/120/120
		Up to 25	48	11.5 mm	25 mm deep both sides with 20 × 20 mm fillet both sides as shown in Figure 10	-/120/120
		Up to 32	60	14 mm	Minimum 25 mm deep both sides finished with 20 mm × 20 mm fillet on both sides as shown in Figure 10	-/120/120
PEX/AL/PEX		Up to 20	60	20 mm	Minimum 25 mm deep both sides finished with 20 mm × 20 mm fillet on both sides as shown in Figure 10	-/120/120
		Up to 20	30	5 mm	25 mm deep both sides finished flush	-/120/120
		Up to 20	40	10 mm	25 mm deep both sides 20×20 mm fillet both sides as shown in Figure 10	-/120/120
		Up to 25	48	11.5 mm	20 mm deep both sides 20×20 mm fillet both sides as shown in Figure 10	-/120/120
		Up to 20	60	20 mm	25 mm deep both sides 20×20 mm fillet both sides as shown in Figure 10	-/120/120
PE-Xb		Up to 25	48	11.5 mm	25 mm depth both sides with 20×20 mm fillet on both sides as shown in Figure 10	-/120/120
		Up to 32	83	25.0 mm	20 mm deep with 15 mm fillet on both sides as shown in Figure 1	-/120/120
cPVC		Up to 32	83	25.0 mm	20 mm deep with 15 mm fillet on both sides as shown in Figure 1	-/120/120
UPVC		Up to 20	24	2 mm	Surface seal only	-/120/120
		Up to 25	40	7.5 mm	25 mm deep with 20×20 mm fillet on both sides as shown in Figure 1	-/120/120
		Up to 32	73	20.5 mm	20 mm deep with 15×15 mm fillet on both sides as shown in Figure 1	-/120/120
		30-40	44	7 mm – 2 mm	10 mm deep with 25×25 mm fillet on both sides. The wall must be built Up with at least 13 mm thick fire rated plasterboard.	-/120/120

6.5 Assessment of various combustible pipes in minimum 130 mm thick CLT wall systems

6.5.1 Proposed construction

Table 14 lists the pipes tested in FRT210330 and EWFA 54783400.2 in accordance with AS 1530.4:2014.

In test FRT 210330, the tested system included 130 mm thick CLT wall system penetrated with 9 services. The combustible pipes protected with BOSS FireMastic-HPE sealant are considered in this section.

In test EWFA 54783400.2, the tested system included 137 mm thick CLT wall system penetrated with various pipe and cable services and protected by various sealants and collars. The combustible pipes protected with BOSS FireMastic-HPE sealant are considered in this section.

Table 14 Tested combustible pipes in CLT wall systems

Services	Reference test	Wall thickness	Nominal pipe diameter (mm)	Annular gap (mm)	Sealant configuration	FRL
PEX-A	FRT210330	130 mm CLT	20 mm	20 mm	20 mm deep both sides finished flush	-/90/90
	EWFA 54783400.2		20.4 mm	12.3 mm	25 mm deep both sides finished flush	-/90/90
PEX/AL/PEX	FRT210330		20 mm	20 mm	20 mm depth both sides finished flush	-/90/60
Kelox plus pipe	FRT210330		50 mm	16.5 mm	20 mm deep both sides finished flush as shown in Figure 9	-/90/90

6.5.2 Discussion

Improvements to insulation performance

Table 14 shows that most of the services maintain integrity and insulation for up to 90 minutes. However, one service failed to achieve 90 minutes insulation performance. In this section, failure causes and improvements will be discussed in the following sections.

In test FRT210330, service F, a 20 mm PEX/AL/PEX pipe was installed within a 60 mm diameter aperture. The annular gap size was 20 mm. The pipe was protected with BOSS FireMastic-HPE sealant, filled to a nominal depth of 20 mm on both sides, and finished flush. At 65 minutes, the thermocouple positioned on the pipe, 25 mm away from the sealant, recorded a temperature of 196 C°. The temperature-time graph showed that for 30 minutes, the sealant could close off the gaps created at the interface between the sealant and the pipe when the pipe started to melt. The temperature recorded for the first 30 minutes was below 50 C°. At approx. 32 minutes, the temperature increased rapidly and reached 196 C° at 65 minutes. This failure is expected to happen due to the metal component of the pipe, which conducts heat and does not melt to allow the sealant to close off the gap that formed when the pipe softened. Therefore, increasing the sealant depth to 25 mm and adding a 50 mm × 50 mm sealant fillet will improve the performance up to 120 minutes.

Since PEX/AL/PEX is expected to be worse performing than PEX, PEX-A and PEX-B pipes due to the aluminium layer within the pipe wall. The outcomes of the assessment can be extended to include PEX, PEX-A and PEX-B pipes.

6.5.3 Conclusion

The technical review found that the combustible pipes protected by BOSS FireMastic-HPE sealant are expected to achieve the fire resistance levels (FRL) given in Table 15 in accordance with AS 1530.4:2014 and assessed in accordance with AS 4072.1:2005.

Table 15 Assessment outcome of combustible pipes in CLT walls

Pipe	Nominal pipe diameter (mm)	Maximum aperture (mm)	Annular gap (mm)	Sealant configuration	FRL
PEX-A	Up to 20	60	20	20 mm deep both sides finished flush	-/90/90
	Up to 20.4	45	12.5	25 mm deep both sides finished flush	-/90/90
PEX/AL/PEX and PE-Xb	Up to 20	60	20	25 mm depth both sides finished with 20 mm x 20 mm fillet	-/90/90
Kelox plus pipe	O.D 50 mm Up to (25+ 13 mm thick insulation)	83	16.5	20 mm deep both sides finished flush	-/90/90

6.6 Assessment of various combustible pipes in Masonry wall with double layer of 50 mm thick “BOSS Fire Batt” aperture – Factory applied “BOSS Ablative Coating” to both faces and PS coating to exposed face.

6.6.1 Proposed construction

Table 16 lists the pipes tested in WARRES 359904 FR in accordance with BS EN 1366-3:2009.

In test WARRES 359904 FR, a 1100 mm high by 750 mm wide aperture was sealed with a double layer of 50 mm thick “BOSS Fire Batt”. The batt was coated on both faces with ablative coating. Each horizontal and vertical cut of the batt to each substrate was sealed with a sealant identical to FireMastic 300. The services penetrated the batt were sealed with BOSS FireMastic-HPE sealant.

Table 16 Tested combustible pipes in a masonry wall with double layer of 50 mm thick “BOSS Fire Batt” aperture

Services	Reference test	Wall thickness	Nominal pipe diameter (mm)	Annular gap (mm)	Sealant configuration	FRL
PEX	WARRES 359904 FR	masonry wall with double layer of 50 mm thick “BOSS Fire Batt” aperture –	40 mm	20 mm	25 mm deep both sides finished flush	-/120/120
	WARRES 359904 FR		110 mm	20 mm	25 mm deep both sides finished flush	-/120/120 U/C
UPVC	WARRES 359904 FR	Factory applied “BOSS Ablative Coating” to both faces and PS coating to exposed face.	50 × 2.4 mm	20 mm	25 mm deep both sides finished flush	-/120/120 U/C
	WARRES 359904 FR		50 × 3.7mm	20 mm	25 mm deep both sides finished flush	-/120/120 U/C
	WARRES 359904 FR		125 × 4.8mm	20 mm	25 mm deep both sides finished flush	-/120/90 U/C

Services	Reference test	Wall thickness	Nominal pipe diameter (mm)	Annular gap (mm)	Sealant configuration	FRL
	WARRES 359904 FR		125 × 7.4mm	20 mm	25 mm deep both sides finished flush	-/120/120 U/C

6.6.2 Discussion

Improvements to insulation performance

Table 16 shows that most of the tested pipes penetrating masonry walls with a double layer of 50 mm thick “BOSS Fire Batt” aperture achieved an FRL of -/120/120. However, a UPVC pipe with a diameter of 125 mm installed in a 20 mm annular gap failed insulation.

Requirements for large apertures

Where specified, services penetrating double layers of 50 mm thick BOSS batts are protected with BOSS FireMastic-HPE sealant installed on both faces. The BOSS batts may be pattress fitted overlapping (minimum 100 mm overlap) the separating element or friction-fitted in the aperture bedded with BOSS FireMastic-HPE sealant. The maximum aperture size in walls is 600 mm × 600 mm.

If the batts are pattress fitted, they must be fixed using suitable screws, fixings and washers to the substrate with minimum 30 mm embedment at maximum 300 centres or at Batt corners, additionally, the pattress fitted batt must overlap the separating element with minimum 50 mm on all four sides. If friction-fitted and bedded within the aperture, the overall size of the batts may be made of cut batt sections butt jointed together and fitted after the pipes are installed. Sealant or ablative coating must be used to bed the cut batts together and to seal the edges of the batt with the separating element and with the pipe. The BOSS batts must be coated on both faces with an ablative coating. Additionally, each vertical and horizontal cut of the batt must be sealed with FireMastic 300 or FireMastic-HPE sealant or ablative coating at the interface between the batts and the service and between the batt and the separating element.

FRLs assessed in flexible walls and rigid walls are applicable to the same services penetrating a large aperture fitted with two layers of 50 mm thick BOSS Batts friction-fitted or pattress fitted on either side, provided that the Batts have been tested or assessed in this configuration to have the minimum established FRL by an ATL.

6.6.3 Conclusion

The technical review found that the combustible pipes protected by BOSS FireMastic-HPE sealant are expected to achieve the fire resistance levels (FRL) given in Table 17 in accordance with AS 1530.4:2014 and assessed in accordance with AS 4072.1:2005.

Table 17 Assessment outcome of combustible pipes in Masonry wall with double layer of 50 mm thick “BOSS Fire Batt” aperture – Factory applied “BOSS Ablative Coating” to both faces and PS coating to exposed face.

Services	Wall thickness	Nominal pipe diameter (mm)	Annular gap (mm)	Sealant configuration	FRL
PEX	masonry wall with double layer of 50 mm thick “BOSS Fire Batt” aperture – Factory applied “BOSS Ablative Coating” to both faces and PS coating to exposed face.	Up to 40 mm	20 mm	25 mm deep both sides finished flush	-/120/120
		Up to 110 mm	20 mm	25 mm deep both sides finished flush	-/120/120 U/C

Services	Wall thickness	Nominal pipe diameter (mm)	Annular gap (mm)	Sealant configuration	FRL
UPVC		Up to 50 × 2.4 mm	20 mm	25 mm deep both sides finished flush	-/120/120 U/C
		Up to 50 × 3.7mm	20 mm	25 mm deep both sides finished flush	-/120/120 U/C
		Up to 125 × 4.8mm	20 mm	25 mm deep both sides finished flush	-/120/90 U/C
		Up to 125 × 7.4mm	20 mm	25 mm deep both sides finished flush	-/120/120 U/C

6.7 Assessment of insulated metal pipes in minimum 116 mm thick flexible wall system

6.7.1 Proposed construction

Table 18 lists the insulated metal pipes tested in FP 10422-001 issue 2 in accordance with AS 1530.4:2014 and ChiltRF 12089A and WF 334037-D in accordance with BS EN 1366-3:2009 and BS EN 1366-4:2009.

In test FP 10422-001 Issue 2, the separating element was a nominally 130 mm thick steel stud wall lined with two layers of 13 mm thick Knauf MultiShield plasterboard on each face. The wall was provided with six apertures and fitted with six pipe penetrations. Each penetration consisted of a single pipe insulated with a mineral fibre insulated pipe section. The pipes ranged in diameter from 25 mm to 324 mm OD, and the pipe materials were steel and copper. For the purpose of this assessment, insulated metal pipes that were protected with BOSS FireMastic HPE sealant will be referenced in this discussion.

In test ChiltRF12089A, a 120 mm thick high steel stud/plasterboard clad partition was built in accordance with BSEN 1366-3. The supporting construction was penetrated with nine service penetrations. The penetrations were sealed with BOSS FireMastic-HPE sealant.

In the reference test WARRES 334037/D, a 100 mm thick plasterboard wall was penetrated with fifteen various combustible and insulated metal services. The Insulated metal pipes were protected with a sealant identical to BOSS FireMastic-HPE sealant.

In test 334037/A, a 100 mm thick plasterboard wall was penetrated with fifteen various combustible and insulated metal services. The Insulated metal pipes and Uponor water valves with and without tap units fitted to project from one side of the partition and protected with a sealant identical to BOSS FireMastic-HPE sealant are assessed in this section.

Table 18 Tested Insulated metal pipes tested in flexible wall systems

Pipe	Reference test	Wall thickness (mm)	Nominal pipe diameter (mm)	Aperture Diameter (mm)	Sealant configuration	FRL
Insulated Copper pipe	ChiltRF12089A	120 mm	15 (with 13 mm thick Armaflex insulation)	65	25 mm deep finished flush on both sides as shown in Figure 4.	Integrity: 120 min Insulation: 120 min

Pipe	Reference test	Wall thickness (mm)	Nominal pipe diameter (mm)	Aperture Diameter (mm)	Sealant configuration	FRL
	FP 10422-001 Issue 2	130 mm	25 (with 25 mm thick stonewool insulation)	98	16 mm deep with 35 mm external cone at wall junction. The insulation wrapping is extended 300 mm on the exposed side and 400 mm on the non exposed side	-/120/120
	ChiltRF12089A	120 mm	60 (with 32 mm thick Armaflex insulation)	164	25 mm deep finished flush on both sides as shown in Figure 4. The insulation wrapping is extended 500 mm from the exposed side and 580 mm from the unexposed side	Integrity: 120 min Insulation: 90 min
	FP 10422-001 Issue 2	130 mm	100 (with 50 mm thick stonewool insulation)	224	16 mm deep with 35 mm external cone at wall junction. The insulation wrapping is extended 400 mm from the exposed side and 400 mm from the unexposed side	-/120/60
	WF 334037/D	100 mm	159 (with 32 mm thick glass wool insulation)	259 mm	25 mm deep finished flush on both sides as shown in Figure 4. The insulation wrapping is extended 300 mm from the exposed side and 650 mm from the unexposed side	Integrity: 120 min Insulation: 30 min

Pipe	Reference test	Wall thickness (mm)	Nominal pipe diameter (mm)	Aperture Diameter (mm)	Sealant configuration	FRL
	WF 334037/D	100 mm	159 (with 30 mm thick Armaflex insulation)	263 mm	25 mm deep with 10 mm fillet on both sides. The insulation wrapping is extended 300 mm from the exposed side and 650 mm from the unexposed side	Integrity: 120 min Insulation: 30 min
Steel Schedule 40 pipe	FP 10422-001 Issue 2	130 mm	324 (with 75 mm thick stonewool insulation)	486 mm	5 mm gap between insulated pipe sections and apertures sealed on both faces	-/90/90
One side penetration						
Uponor water valves with tap unit fitted to project from the unexposed face of the partition	WARRES 334037/A	100 mm	52 mm diameter	2 no. 75 mm diameter	25 mm deep and finished flush with the exposed face of the wall	Integrity: 120 min Insulation: 120 min
Uponor water valves with tap unit fitted to project from the exposed face of the partition	WARRES 334037/A	100 mm	52 mm diameter	2 no. 75 mm diameter	25 mm deep and finished flush with the unexposed face of the wall	Integrity: 120 min Insulation: 120 min
Uponor water valves fitted to project from the unexposed face of the partition	WARRES 334037/A	100 mm	52 mm diameter	2 no. 75 mm diameter	25 mm deep and finished flush with the unexposed face of the wall	Integrity: 120 min Insulation: 120 min
Uponor water valves fitted to project from the exposed face of the partition	WARRES 334037/A	100 mm	52 mm diameter	2 no. 75 mm diameter	25 mm deep and finished flush with the exposed face of the wall	Integrity: 120 min Insulation: 120 min

6.7.2 Discussion

Improvements to insulation performance

Table 18 shows that some insulated metal pipes failed insulation. The failure cause and suggested improvements to the sealant configuration to enhance the insulation performance will be discussed in this section.

In test ChiltRF 12089A, specimen 21, a 164 mm diameter aperture was made in a 122 mm thick plasterboard wall system. The aperture was penetrated with 60 mm diameter copper pipe with 32 mm thick Armaflex insulation fitted around the pipe. The annular gap was filled with BOSS FireMastic-HPE sealant to a 25 mm depth and finished flush from both exposed and unexposed sides. The system maintained its integrity and insulation performance for 132 minutes and 106 minutes, respectively. The insulation failure occurred due to the thermocouple positioned on the pipe recording a temperature difference of higher than 180°C. The temperature graph shows that, at 106 minutes the service experienced a steep increase in temperature and reached approximately 250 C° at around 115 minutes. It is considered that this failure is related to the nature of the service, which will heat up and conduct heat from the fire side to the non-fire side. In order to mitigate the expected temperature increase on the non-fire side, the service must be further wrapped with P40-MAK wrap for a length of 600 mm from the separating element on either side. Accordingly, the insulation performance can be extended to 120 minutes.

In test FP 10422-001 issue 2, service Y2, a 224 mm aperture was made in a 130 mm plasterboard wall. The hole was penetrated with 100 mm diameter copper pipe with 50 mm thick stonewool insulation. The insulation wrapping extended 400 mm from the exposed side and 400 mm from the unexposed side. The annular gap was filled with BOSS FireMastic-HPE sealant applied to a depth of 16 mm with a 35 mm external cone at wall junction. The service achieved an integrity and insulation performance of 120 minutes and 60 minutes, respectively. After review of the temperature vs time curve, it was observed that the thermocouple positioned on the pipe recorded a temperature increase of 180°C at 62 minutes. The failure was attributed to the insufficient length of insulation wrapping. To maintain the insulation performance up to 120 minutes, it is proposed to increase the length of the insulation wrapping by an additional 200 mm for a total of 600 mm. When insulating a bigger pipe section, the thermocouple will be moved further from the hot side, and hence it is expected to record a lower temperature. As the attributed FRL is for fire exposure from either side, the wrap length extension must be identical on both sides.

In test WF 334037-D service 10, a 259 mm aperture was made in a 100 mm thick plasterboard wall system. The penetration was fitted with 159 mm diameter copper pipe with 32 mm thick foil faced glasswool insulation which extended 300 mm on the exposed side and 650 mm on the unexposed side. The annular gap was filled with a sealant identical to BOSS FireMastic-HPE sealant to a depth of 25 mm on both sides and finished with a fillet applied around the insulation to a nominal distance of 10 mm from the outer face of the wall. When tested, the service achieved an FRL of -/120/30. The service failed insulation at 43 minutes as the thermocouple placed on the bare pipe recorded a temperature increase of more than 180°C. It is proposed to increase the length of the insulation wrapping to a 1000 mm on both sides. When insulating bigger pipe section, the thermocouple will be moved further from the hot side and hence it is expected to record lower temperature.

In test WF 334037-D service 12, a 263 mm aperture was made in a 100 mm thick plasterboard wall system. The penetration was fitted with 159 diameter copper pipes with 32 mm thick Armaflex insulation extended 300 mm on the exposed side and 650 mm in the unexposed side. The annular gap was filled with sealant identical to BOSS FireMastic-HPE sealant to a depth of 25 mm applied to both sides finished with 10 mm 10 mm sealant fillet. The service achieved an FRL of -/120/30. The service failed insulation at 37 minutes as the thermocouple placed on the bare pipe recorded higher temperature than 180 C° from the ambient temperature. It is proposed to increase the length of the insulation wrapping to a 1000 mm on both sides. When insulating bigger pipe section, the thermocouple will be moved further from the hot side, and hence it is expected to record a lower temperature.

Assessment of various insulated metal pipe sizes

It is proposed to assess various insulated metal pipe sizes up to the tested size. It is expected that The rate of heat transfer through smaller service sizes is lower. As a result, an FRL of -/120/120 is

expected to be maintained if the pipe insulation thickness remains the same and the same sealant configuration is maintained as discussed above.

Assessment of separating element with penetration from one side

A 100 mm thick plasterboard wall was penetrated from one side with uponor water valves with tap unit and protected with a sealant identical to BOSS FireMastic-HPE sealant. The wall construction consisted of 2 layers of plasterboard fixed on both sides on 50 mm wide steel framing. The annular gap between the service and the aperture was filled with BOSS FireMastic-HPE sealant to a depth of 25 mm and finished flush with the wall. It is expected that the penetration from one side will be less onerous than from two sides. In the same test, bigger pipe diameters were tested and achieved an FRL of -/120/120. Therefore, it is expected that a valve of diameter up to 52 mm will at least perform similarly and hence achieve an FRL of -/120/120.

6.7.3 Conclusion

The technical review found that the insulated metal pipes protected by BOSS FireMastic-HPE sealant are expected to achieve the fire resistance levels (FRL) given in Table 19 in accordance with AS 1530.4:2014 and assessed in accordance with AS 4072.1:2005.

Table 19 Assessment outcomes of Insulated metal pipes fitted in minimum 116 mm thick flexible and rigid walls

Pipe	Wall thickness (mm)	Nominal pipe diameter (mm)	Aperture Diameter (mm)	Sealant configuration	FRL
Insulated Copper pipe	120 mm	Up to 15 mm (with 13 mm thick Armaflex insulation)	65	25 mm deep finished flush.	-/120/120
	125 mm	Up to 25 mm (with 25 mm thick stonewool insulation)	98	16 mm deep with 35 mm external cone at wall junction. The insulation wrapping is extended 400 mm on the both sides of the wall	-/120/120
	120 mm	Up to 60 mm (with 32 mm thick Armaflex insulation)	164	25 mm deep finished flush and further wrapped with P40 MAK wrap extending 600 mm from the face of the separating element on both sides.	-/120/120
	135 mm	Up to 100 mm (with 50 mm thick stone wool insulation)	224	16 mm deep with 35 mm external cone at wall junction. Stone wool insulation must be extending from the separating element for at least 600 mm on each side.	-/120/120
	100 mm	Up to 159 mm (With 32 mm thick glass wool insulation)	259	25 mm deep both sides finished flush. The insulation wrapping is to be extended 1000 mm on both sides	-/120/120
	100 mm	Up to 159 mm (With 32 mm thick Armaflex insulation)	263	25 mm deep with 10 10 mm fillet on both sides. The insulation wrapping is to be extended 1000 mm on both sides	-/120/120

Pipe	Wall thickness (mm)	Nominal pipe diameter (mm)	Aperture Diameter (mm)	Sealant configuration	FRL
Steel Schedule 40 pipe	135 mm	Up to 324 mm (with 75 mm thick insulation)	486	5 mm gap between insulated pipe sections and apertures sealed on both faces. The insulation wrapping is extended 400 mm on both sides	-/90/90
Uponor water valves with tap unit fitted to project from the unexposed face of the partition	100 mm	Up to 52 mm diameter	2 no. 75 mm diameter	25 mm deep and finished flush with the exposed face of the wall	-/120/120
Uponor water valves with tap unit fitted to project from the exposed face of the partition	100 mm	Up to 52 mm diameter	2 no. 75 mm diameter	25 mm deep and finished flush with the unexposed face of the wall	-/120/120
Uponor water valves fitted to project from the unexposed face of the partition	100 mm	Up to 52 mm diameter	2 no. 75 mm diameter	25 mm deep and finished flush with the unexposed face of the wall	-/120/120
Uponor water valves fitted to project from the exposed face of the partition	100 mm	Up to 52 mm diameter	2 no. 75 mm diameter	25 mm deep and finished flush with the exposed face of the wall	-/120/120

6.8 Assessment of insulated metal pipes penetrating double layer of 50 mm thick BOSS fire batt installed in a minimum 116 mm flexible and rigid walls

6.8.1 Proposed construction

Table 20 lists the pipes tested in WF 329129 and WARRES 359904 FR in accordance with EN 1366-3:2009.

In test WF 329129, a 100 mm thick drywall construction was provided with four apertures of overall nominal dimensions of 600 mm high by 600 mm wide. The apertures were penetrated with various services and locally protected with various fire protections. In this section of the report, the insulated metal pipes protected with BOSS FireMastic-HPE sealant are discussed.

In test WARRES 359904 FR, a 1100 mm high by 750 mm wide aperture was sealed with a double layer of 50 mm thick "BOSS Fire Batt". The batt was coated on both faces with ablative coating. Each horizontal and vertical cut of the batt to each substrate was sealed with a sealant identical to BOSS FireMastic 300. The services that penetrated the batt were sealed with BOSS FireMastic-HPE sealant.

Table 20 Metal pipes fitted in a double layer of 50 mm thick BOSS fire batt installed in a minimum 116 mm flexible wall

Pipe	Reference test	Nominal pipe diameter (mm)	Maximum aperture (mm)	Sealant configuration	Fire resistance performance
Insulated copper pipe	WF 329129	40 (with 20 mm thick foil faced glass wool insulation)	600 × 600	15 mm deep from the outer face on both sides	Integrity: 60 min Insulation: 60 min
	WF 329129	159 (with 30 mm thick foil faced glass wool insulation)	600 × 600	15 mm deep from the outer face on both sides	Integrity: 60 min Insulation: 30 min
Steel pipe	WF 329129	40 (with 30 mm thick foil faced glass wool insulation)	600 × 600	15 mm deep from the outer face on both sides	Integrity: 60 min Insulation: 60 min
	WF 329129	150 (with 30 mm thick foil faced glass wool insulation)	600 × 600	15 mm deep from the outer face on both sides	Integrity: 60 min Insulation: 60 min

6.8.2 Discussion

Assessment of Intermediate sizes

Table 20 lists the insulated metal pipes that were fitted in a double layer of 50 mm thick BOSS fire batt installed in a minimum 116 mm flexible and rigid walls. In test WF 329129, the tested specimen A was a 40 mm diameter insulated copper pipe wrapped with 20 mm thick foil faced glass wool insulation and locally protected with BOSS FireMastic-HPE sealant applied to a depth of 15 mm from the outer face on both sides. When tested, the specimen continued to maintain its integrity and insulation performance for 76 minutes and 74 minutes, respectively. The test was conducted in accordance with EN 1366-3:2009. A correlation between the test standard and AS 1530.4:2014 was established in section 5, and accordingly an FRL of -/60/60 is attributed to the 40 mm diameter insulated copper pipe.

In the same test, a 159 mm diameter copper pipe with 30 mm thick foil faced glass wool insulation was tested with BOSS FireMastic-HPE sealant applied 15 mm deep from the outer face of the batt on both sides. When tested, the specimen continued to maintain its integrity and insulation performance for 76 minutes and 59 minutes, respectively. It is considered that if the sealant depth is increased from 15 mm to the full depth of the batt, the insulation performance is expected to improve for at least more than 1 minute. Accordingly, an insulation performance of 60 minutes can be maintained.

Moreover, it is proposed to extend the achieved FRL to cover intermediate pipe sizes. The tested specimens included diameter pipe sizes from 40 mm to 159 mm. Accordingly, it is reasonable to consider that any pipe within this diameter range is expected to achieve the FRL shown in Table 21, provided that the pipe insulation thickness remains the same as tested and the sealant configuration is as instructed in Table 21.

Assessment of Iron pipes

It is noted that the referenced WF 329129 test was conducted using steel pipes, and it is proposed to assess the results using pipes made of cast iron. It is understood that both materials have very similar thermal conductivity properties, as they are primarily composed of iron. The main difference is that steel is an alloy of iron and carbon. Based on the observations from the referenced test, it is considered that, due to the glasswool insulation, the impact of furnace exposure will largely remain unchanged between steel and iron. This is because the sealant will maintain contact with the pipe insulation regardless of the pipe material used when considering iron pipes.

6.8.3 Conclusion

The technical review found that the insulated metal pipes protected by BOSS FireMastic-HPE sealant are expected to achieve the fire resistance levels (FRL) given in Table 21, in accordance with AS 1530.4:2014, and assessed in accordance with AS 4072.1:2005.

Table 21 Assessment outcome of insulated metal pipe penetrating double layer of 50 mm thick BOSS fire batt installed in a minimum 116 mm flexible and rigid walls

Pipe	Nominal pipe diameter (mm)	Maximum aperture (mm)	Sealant configuration	FRL
Insulated copper pipe	Up to 40 (with 20 mm thick foil faced glass wool insulation)	600 × 600	15 mm deep from the outer face on both sides	-/60/60
	Up to 159 (with 30 mm thick foil faced glass wool insulation)	600 × 600	15 mm deep from the outer face on both sides	-/60/30
			Full depth of batt	-/60/60
Steel or Iron pipes	Up to 40 (with 30 mm thick foil faced glass wool insulation)	600 × 600	15 mm deep from the outer face on both sides	-/60/60
	Up to 150 (with 30 mm thick foil faced glass wool insulation)	600 × 600	15 mm deep from the outer face on both sides	-/60/60

6.9 Assessment of various combustible pipes in minimum 235 mm thick ceiling systems

6.9.1 Proposed construction

Table 22 lists the pipes tested in FRT180474.3 in accordance with AS 1530.4:2014.

In the reference test FRT180474.3, a 235 mm thick ceiling system was penetrated with 10 services and protected with various local fire stopping protections. The ceiling consisted of 2 layers of 13 mm fire-rated plasterboard directly fixed to the timber framing on the exposed side using plasterboard screws at nominal 150 mm centres on the joist and 100 mm centres on the perimeter framing. On the unexposed side, particleboard flooring was fixed directly onto the timber framing. The sealant used in the ceiling system was BOSS FireMastic-HPE sealant, and the sealant used in the timber flooring system was BOSS FireMastic-300. This section will discuss the combustible pipes protected with BOSS FireMastic-HPE sealant only.

Table 22 Tested combustible pipes in ceiling system

Services	Reference test	Nominal pipe diameter (mm)	Annular gap (mm)	Sealant configuration	RISF	FRL
PVC	FRT180474.3	25 mm	19 mm	BOSS FireMastic-HPE – applied to full depth of the plasterboard and finished flush on the exposed side. BOSS FireMastic 300 to depth of board in the unexposed side	Failure at 55 minutes	-/90/90

6.9.2 Discussion

Assessment of various pipe sizes

In test FRT180474.3, service G, a 63 mm aperture was made in a 235 mm thick ceiling system. The aperture was penetrated with 25 mm diameter PVC pipe. The annular gap between the service and the separating element was filled with BOSS FireMastic-HPE sealant to a depth of 26 mm and finished flush on the exposed side. On the unexposed side, BOSS FireMastic 300 sealant was used to fill the annular gap to the depth of the board. The RISF thermocouple that was placed on the service at 25 mm from the aperture failed at 55 minutes. However, the service-maintained integrity and insulation performance for 90 minutes. It is proposed to assess smaller PVC sizes installed in a similar configuration. With smaller PVC pipes, it is expected that the intumescent sealant will close off the smaller pipe size quicker and, hence, restrict the passage of hot gases. Based on the above, using a smaller size service penetration is positively assessed provided that the annular gap is not increased, and the sealant configuration is maintained as tested.

6.9.3 Conclusion

The technical review found that the combustible pipes protected by BOSS FireMastic-HPE sealant are expected to achieve the fire resistance levels (FRL) given in Table 23, in accordance with AS 1530.4:2014, and assessed in accordance with AS 4072.1:2005.

Table 23 Assessment outcome of combustible pipes in ceiling system

Services	Nominal pipe diameter (mm)	Annular gap (mm)	Sealant configuration	RISF	FRL
PVC	Up to 25 mm	Up to 19 mm	BOSS FireMastic-HPE – applied to full depth of the plasterboard and finished flush on the exposed side. BOSS FireMastic 300 to depth of board in the unexposed side	Failure at 55 minutes	-/90/90

6.10 Assessment of various combustible pipes in minimum 150 mm thick AAC floor

6.10.1 Proposed construction

Table 24 lists the pipes tested in WARRES 342026 and WARRES 359904 FR in accordance with BS EN 1366-3:2009.

In test WARRES 342026, the tested floor had a dimension of 2230 mm long by 1740 mm wide by 150 mm thick and was provided with ten circular apertures of varying sizes penetrated with various services. In this section, combustible pipes protected with a sealant identical to BOSS FireMastic-HPE sealant will be considered.

In test WARRES 359904 FR, a 1100 mm high by 750 mm wide aperture was sealed with a double layer of 50 mm thick “BOSS Fire Batt”. The batt was coated on both faces with ablative coating. Each horizontal and vertical cut of the batt to each substrate was sealed with a sealant identical to BOSS firemastic 300. The services penetrated the batt were sealed with BOSS FireMastic-HPE sealant.

Table 24 Tested combustible pipes in AAC floor

Services	Reference test	Floor thickness	Nominal pipe diameter (mm)	Annular gap (mm)	Sealant configuration	Fire resistance performance
PEX	WARRES 359904 FR	150 mm AAC floor	40 mm × 4 mm	20 mm	25 mm deep both sides finished flush	integrity: 120 min Insulation:120 min
	WARRES 359904 FR		110 mm × 10 mm	20 mm	25 mm deep both sides finished flush	integrity: 120 min Insulation:60 min
PP	WARRES 342026	150 mm AAC floor	50 mm × 2.1 mm	21 mm	25 mm depth finished flush on both sides. Included 100 mm deep infill friction fitted stone wool insulation	integrity: 240 min Insulation:240 min
	WARRES 342026		110 mm × 10.7 mm	21 mm	25 mm depth finished flush on both sides. Included 100 mm deep infill friction fitted stone wool insulation	integrity: 120 min Insulation: 120 min
	WARRES 342026		110 mm × 3.7 mm	21 mm	25 mm depth finished flush on both sides. Included 100 mm deep infill friction fitted stone wool insulation	integrity: 30 min Insulation:30 min
PE	WARRES 342026	150 mm AAC floor	40 mm × 4.1 mm	18.5 mm	25 mm depth finished flush on both sides. Included 100 mm deep infill friction fitted stone wool insulation	integrity: 240 min Insulation:240 min
	WARRES 342026		125 × 7.6 mm	13.5 mm	25 mm depth finished flush on both sides. Included 100 mm deep infill friction fitted stone wool insulation	integrity: 60 min Insulation:60 min
	WARRES 342026		125 × 11.4 mm	13.5 mm	25 mm depth finished flush on both sides. Included 100 mm deep infill friction fitted stone wool insulation	integrity: 90 min Insulation:90 min
PVC	WARRES 342026	150 mm AAC floor	40 mm × 2 mm	18.5 mm	25 mm depth finished flush on both sides. Included 100 mm deep infill friction fitted stone wool insulation	integrity: 240 min Insulation:240 min
	WARRES 342026		114 mm × 3.6 mm	25.5 mm	25 mm depth finished flush on both sides. Included 100 mm deep infill friction fitted stone wool insulation	integrity: 90 min Insulation:30 min
	WARRES 342026		114 mm × 8.1 mm	25.5 mm	25 mm depth finished flush on both sides. Included 100 mm deep infill friction fitted stone wool insulation	integrity: 120 min Insulation:30 min

Services	Reference test	Floor thickness	Nominal pipe diameter (mm)	Annular gap (mm)	Sealant configuration	Fire resistance performance
	WARRES 359904 FR		50 mm × 3.7 mm	20 mm	25 mm depth both sides with backing rod finished flush	integrity: 120 min Insulation: 120 min
	WARRES 359904 FR		50 mm × 2.4 mm	20 mm	25 mm depth both sides with backing rod finished flush	integrity: 120 min Insulation: 120 min
	WARRES 359904 FR		125 mm × 4.8 mm	20 mm	25 mm depth both sides with backing rod finished flush	integrity: 120 min Insulation: 90 min
	WARRES 359904 FR		125 mm × 7.4 mm	20 mm	25 mm depth both sides with backing rod finished flush	integrity: 120 min Insulation: 120 min

6.10.2 Discussion

Assessment of various pipe sizes

It is proposed to assess smaller pipe sizes. It is expected that BOSS FireMastic-HPE sealant will close off the smaller pipe size quicker and more efficiently, thereby restricting the passage of hot gases – through the gaps formed when the pipe softened due to heat – at an earlier time. Therefore, using a smaller size service penetration is positively assessed provided that the annular gap is not increased and the sealant configuration is maintained as tested. Furthermore, the tested pipe configuration was uncapped from the exposed side and capped from the unexposed side (U/C); therefore, and as per the discussion provided in section 5, the achieved FRL is limited to U/C and C/C only.

6.10.3 Conclusion

The technical review found that the combustible pipes protected by BOSS FireMastic-HPE sealant are expected to achieve the fire resistance levels (FRL) given in Table 25 – in accordance with AS 1530.4:2014, and assessed in accordance with AS 4072.1:2005.

Table 25 Assessment outcome of combustible pipes in AAC floor system

Services	Floor thickness	Nominal pipe diameter (mm)	Annular gap (mm)	Sealant configuration	FRL
PEX	150 mm AAC floor	Up to 40 mm with minimum 4 mm pipe wall thickness	20 mm	25 mm deep both sides finished flush	-/120/120
		110 mm × 10 mm	20 mm	25 mm deep both sides finished flush	-/120/60
PP	150 mm AAC floor	UP to 50 mm	10 to 21 mm	25 mm depth finished flush on both sides. Included 100 mm deep infill friction fitted stone wool insulation	-/240/240 U/C and C/C
		Up to 110 mm × 10.7 mm	10 to 21 mm	25 mm depth finished flush on both sides. Included 100 mm deep infill friction fitted stone wool insulation	-/120/120 U/C and C/C

Services	Floor thickness	Nominal pipe diameter (mm)	Annular gap (mm)	Sealant configuration	FRL
		Up to 110 mm × 3.7 mm	10 to 21 mm	25 mm depth finished flush on both sides. Included 100 mm deep infill friction fitted stone wool insulation	-/30/30 U/C and C/C
PE		UP to 40 mm	10 to 18.5 mm	25 mm depth finished flush on both sides. Included 100 mm deep infill friction fitted stone wool insulation	-/240/240 U/C and C/C
		Up to 125 × 7.6 mm	10 to 13.5 mm	25 mm depth finished flush on both sides. Included 100 mm deep infill friction fitted stone wool insulation	-/60/60 U/C and C/C
		125 × 11.4 mm	10 to 13.5 mm	25 mm depth finished flush on both sides. Included 100 mm deep infill friction fitted stone wool insulation	-/90/90 U/C and C/C
PVC		Up to 40 × 2 mm	UP to 18.5 mm	25 mm depth finished flush on both sides. Included 100 mm deep infill friction fitted stone wool insulation	-/240/240 U/C and C/C
		Up to 114 mm × 3.6 mm	25.5 mm	25 mm depth finished flush on both sides. Included 100 mm deep infill friction fitted stone wool insulation	-/90/30
		Up to 114 mm × 8.1 mm	25.5 mm	25 mm depth finished flush on both sides. Included 100 mm deep infill friction fitted stone wool insulation	-/120/30
		50 mm × 3.7 mm	20 mm	25 mm depth both sides with backing rod finished flush	-/120/120
		50 mm × 2.4 mm	20 mm	25 mm depth both sides with backing rod finished flush	-/120/120
		125 mm × 4.8 mm	20 mm	25 mm depth both sides with backing rod finished flush	-/120/90
		125 mm × 7.4 mm	20 mm	25 mm depth both sides with backing rod finished flush	-/120/120

6.11 Assessment of various combustible pipes in minimum 150 mm thick concrete floor

6.11.1 Proposed construction

Table 26 lists the tested combustible pipes in 150 mm thick concrete floor in accordance with AS 1530.4:2014.

In the reference test FRT220049, a 150 mm concrete floor system was tested. The slab was penetrated by 10 various services. The services were protected with different fire stopping protections. This section discusses the HVAC service penetration protected with BOSS FireMastic-HPE sealant.

Table 26 Tested combustible pipes in minimum 150 mm thick concrete slab

Pipe	Reference test	Nominal pipe diameter (mm)	Maximum aperture (mm)	Sealant configuration	Fire resistance performance
uPVC	FRT220049 R1.0	20 mm	50 mm	FireMAstic-HPE sealant was applied into the annular gap at the depth of 25 mm and finished flush with the separating element on both sides.	-/240/240
		32 mm	50 mm	The sealant was supported by 10 mm diameter polyethylene backing rods.	
PEX-Xa	FRT220049 R1.0	20 mm	40 mm	FireMAstic-HPE sealant was applied into the annular gap at the depth of 25 mm and finished flush with the separating element on both sides. The sealant was supported by 10 mm diameter polyethylene backing rods.	-/240/240
PEX/AL/PEX		20 mm	40 mm	FireMAstic-HPE sealant was applied into the annular gap at the depth of 25 mm and finished flush with the separating element on both sides. The sealant was supported by 10 mm diameter polyethylene backing rods.	

6.11.2 Discussion

Assessment of various pipe sizes

It is proposed to assess smaller pipe sizes. It is expected that BOSS FireMastic-HPE sealant will close off the smaller pipe size quicker and more efficiently, thereby restricting the passage of hot gases – through the gaps formed when the pipe softened due to heat – at an earlier time. Therefore, using a smaller size service penetration is positively assessed provided that the annular gap is not increased and the sealant configuration is maintained as tested.

6.11.3 Conclusion

The technical review found that the combustible pipes protected by BOSS FireMastic-HPE sealant are expected to achieve the fire resistance levels (FRL) given in Table 29 – in accordance with AS 1530.4:2014 and assessed in accordance with AS 4072.1:2005.

Table 27 Assessment outcomes of combustible pipes in minimum 150 mm thick concrete floor

Pipe	Reference test	Nominal pipe diameter (mm)	Maximum aperture (mm)	Sealant configuration	Fire resistance performance
uPVC	FRT220049 R1.0	Up to 32 mm	50 mm	FireMAstic-HPE sealant was applied into the annular gap at the depth of 25 mm and finished flush with the separating element on both sides. The sealant was supported by 10 mm diameter polyethylene backing rods.	-/240/240
PEX-Xa		Up to 20 mm	40 mm	FireMAstic-HPE sealant was applied into the annular gap at the depth of 25 mm and finished flush with the separating element on both sides. The sealant was supported by 10 mm diameter polyethylene backing rods.	-/240/240
PEX/AL/PEX		Up to 20 mm	40 mm	FireMAstic-HPE sealant was applied into the annular gap at the depth of 25 mm and finished flush with the separating element on both sides. The sealant was supported by 10 mm diameter polyethylene backing rods.	-/240/240
PEX	WARRES 359904 FR	40 mm × 4 mm	20 mm	25 mm deep both sides finished flush	integrity: 120 min Insulation:120 min
		110 mm × 10 mm	20 mm	25 mm deep both sides finished flush	integrity: 120 min Insulation:60 min
PP	WARRES 342026	50 mm × 2.1 mm	21 mm	25 mm depth finished flush on both sides. Included 100 mm deep infill friction fitted stone wool insulation	integrity: 240 min Insulation:240 min

Pipe	Reference test	Nominal pipe diameter (mm)	Maximum aperture (mm)	Sealant configuration	Fire resistance performance
		110 mm × 10.7 mm	21 mm	25 mm depth finished flush on both sides. Included 100 mm deep infill friction fitted stone wool insulation	integrity: 120 min Insulation: 120 min
		110 mm × 3.7 mm	21 mm	25 mm depth finished flush on both sides. Included 100 mm deep infill friction fitted stone wool insulation	integrity: 30 min Insulation: 30 min
PE	WARRES 342026	40 mm × 4.1 mm	18.5 mm	25 mm depth finished flush on both sides. Included 100 mm deep infill friction fitted stone wool insulation	integrity: 240 min Insulation: 240 min
		125 × 7.6 mm	13.5 mm	25 mm depth finished flush on both sides. Included 100 mm deep infill friction fitted stone wool insulation	integrity: 60 min Insulation: 60 min
		125 × 11.4 mm	13.5 mm	25 mm depth finished flush on both sides. Included 100 mm deep infill friction fitted stone wool insulation	integrity: 90 min Insulation: 90 min
PVC	WARRES 342026	40 mm × 2 mm	18.5 mm	25 mm depth finished flush on both sides. Included 100 mm deep infill friction fitted stone wool insulation	integrity: 240 min Insulation: 240 min
		114 mm × 3.6 mm	25.5 mm	25 mm depth finished flush on both sides. Included 100 mm deep infill friction fitted stone wool insulation	integrity: 90 min Insulation: 30 min
		114 mm × 8.1 mm	25.5 mm	25 mm depth finished flush on both sides. Included 100 mm deep infill friction fitted stone wool insulation	integrity: 120 min Insulation: 30 min

Pipe	Reference test	Nominal pipe diameter (mm)	Maximum aperture (mm)	Sealant configuration	Fire resistance performance
		50 mm × 3.7 mm	20 mm	25 mm depth both sides with backing rod finished flush	integrity: 120 min Insulation: 120 min
		50 mm × 2.4 mm	20 mm	25 mm depth both sides with backing rod finished flush	integrity: 120 min Insulation: 120 min
		125 mm × 4.8 mm	20 mm	25 mm depth both sides with backing rod finished flush	integrity: 120 min Insulation: 90 min
		125 mm × 7.4 mm	20 mm	25 mm depth both sides with backing rod finished flush	integrity: 120 min Insulation: 120 min

6.12 Assessment of insulated metal pipes in a minimum 125 mm concrete slab

6.12.1 Proposed construction

Table 28 lists insulated metal pipes tested in FP 10422-002 Issue 2 in accordance with AS 1530.4:2014 and WF 342025 in accordance with EN 1366-3:2009.

In test FP 10422-002 Issue 2, a 125 mm thick floor slab was provided with six core drilled apertures and fitted with six pipe penetrations. Each penetration consisted of a single pipe insulated with a mineral fibre insulated pipe section. The pipes ranged in diameter from 25 mm to 324 mm OD, and the pipe materials were steel and copper.

In test WF 342025, a 150 mm thick concrete floor was provided with five 200 mm by 200 mm apertures and one 50 mm by 50 mm aperture, each penetrated with various cables and services. The floor was also provided with four circular apertures, each penetrated by a range of insulated steel and copper pipes.

Table 28 Insulated metal pipes in concrete slab

Pipe	Reference test	Nominal pipe diameter (mm)	Maximum aperture (mm)	Sealant configuration	Fire resistance performance
Insulated copper pipe	FP 10422-002 Issue 2	25 (With 25 mm thick insulation)	98 mm	16 mm deep with 10 mm external cone at wall junction	Integrity: 120 min Insulation: 120 min
	FP 10422-002 Issue 2	100 (With 50 mm thick insulation)	224 mm	16 mm deep with 10 mm external cone at junction	Integrity: 120 min Insulation: 90 min
	WF 342025	200 (With 32 mm thick insulation)	304 mm	25 mm depth to unexposed side backed with stonewool insulation	Integrity: 60 min Insulation: 30 min

Pipe	Reference test	Nominal pipe diameter (mm)	Maximum aperture (mm)	Sealant configuration	Fire resistance performance
Blank seal	WF 342026	NA	Aperture size of 200 mm × 200 mm	25 mm deep sealant, applied flush with the upper face of the floor and includes a 100 mm deep infill of friction fitted rock wool insulation of density of no less than 45 kg/m ³ .	Integrity: 240 min Insulation: 236 min

6.12.2 Discussion

Improvements to insulation performance

In test FP 10422-002 Issue 2, specimen FX2, a 100 mm diameter copper pipe was installed in a core hole of size 224 mm. 50 mm thick insulation was wrapped around the copper pipe and extended 400 mm on the exposed face and 600 mm in the unexposed face. BOSS FireMastic-HPE sealant was applied at insulation and pipe joints to a depth of 16 mm. At 115 minutes, a split in the sealant was evident, and the temperature – recorded by the thermocouple placed on the pipe – reached 180 C° and increased rapidly and reached 300 C° at approx. 124 minutes. It is suggested to extend the pipe insulation on the unexposed side to 800 mm to improve the system insulation performance up to 120 minutes.

Assessment of intermediate pipe sizes

In test FP 10422-002 Issue 2, service FX3, a 25 mm diameter copper pipe was installed within a 98 mm aperture. The pipe was wrapped with 25 mm thick stone wool sectional pipe insulation extended 300 mm on both exposed and unexposed sides. The annular gap between the pipe insulation and concrete slab was protected with 16 mm deep BOSS FireMastic-HPE sealant and a 10 mm 10 mm fillet at the junction. This configuration achieved an FRL of -/120/120. It is proposed to assess the intermediate pipe sizes between 25 mm and 100 mm based on the performance of the tested pipes. It is expected that the assessment of intermediate sizes can be positive if the pipe is wrapped with 50 mm thick insulation extended 400 mm on the exposed side and 800 mm on the unexposed side. A 10 mm annular gap is maintained all around the services. Additionally, a BOSS FireMastic-HPE sealant is applied to the annular gap to a depth of 16 mm on both sides, and a 10 mm × 10 mm cone is added on both sides as well.

In test WF 342025, service E, a 304 mm aperture was made in a 150 mm thick concrete floor. The aperture was penetrated with 200 mm diameter by 5 mm wall thickness steel pipe, insulated with 32 mm thick Armaflex elastomeric pipe insulation (CS). The aperture was sealed using a 25 mm depth of a sealant identical to BOSS FireMastic-HPE sealant, finished flush with the upper face of the floor and include a 100 deep infill of friction fitted stone wool insulation of a measured density of 45 kg/m³. The service failed integrity at 68 minutes, as a glow from within the seal was evident and the applied cotton pad was ignited. The service failed insulation at 47 minutes as a result of a separation increase of Armaflex around the pipe from the point of penetration.

It is proposed to assess the pipe sizes between 100 mm and 200 mm. The intermediate sizes must have the pipe insulation thickness maintained as tested and be wrapped with 32 mm thick insulation, and the sealant configuration must be maintained as tested.

Assessment of different pipe material

The results of test FP 10422-002 Issue 2 and the assessment outcomes can be extended to cover insulated steel pipes. Steel has a higher melting point and thermal stability compared to copper, which keeps the system in place for a relatively longer time and allows sufficient time for the sealant to expand and close off the gaps formed when the pipe starts to deform under the effects of severe heat

conditions. Additionally, copper is an excellent thermal conductor, so it conducts more heat to the unexposed side and is hence more susceptible to failing insulation earlier than steel.

6.12.3 Conclusion

The technical review found that the combustible pipes protected by BOSS FireMastic-HPE sealant are expected to achieve the fire resistance levels (FRL) given in Table 29 – in accordance with AS 1530.4:2014 and assessed in accordance with AS 4072.1:2005.

Table 29 Assessment outcome of insulated metal pipes in concrete slab

Pipe	Nominal pipe diameter (mm)	Annular gap (mm)	Sealant configuration	FRL
Insulated copper pipe	Up to 25 (With 25 mm thick insulation)	10 mm	16 mm deep with 10 mm external cone at wall junction	-/120/120
	25- 100 (With insulation thickness 25 mm-50 mm)	10	16 mm deep with 10 mm external cone at wall junction	-/120/90
	Up to 100 (With 50 mm thick insulation)	10	16 mm deep with 10 mm external cone at junction	-/120/90
	100-200(32 mm thick insulation)	20	25 mm deep on unexposed only backed with stonewool insulation.	-/60/30
Blank seal	NA	Aperture size of 200 mm x 200 mm	25 mm deep sealant, applied flush with the upper face of the floor and includes a 100 mm deep infill of friction fitted rock wool insulation of density of no less than 45 kg/m ³ .	-/240/180
			30 mm deep sealant, applied flush with the upper face of the floor and includes a 100 mm deep infill of friction fitted rock wool insulation of density of no less than 45 kg/m ³ . The concrete floor must be minimum 175 mm.	-/240/240

7. Assessment of various cables protected with BOSS FireMastic–HPE sealant

7.1 Description of variation

It is proposed that cables penetrating flexible and rigid walls, rigid floors and ceiling constructions are assessed to be protected with BOSS FireMastic-HPE sealant.

In this section, cables protected with BOSS FireMastic-HPE sealant are assessed. The cables considered in this assessment include fire alarm cable, RG6 Coax, CAT6, Core security cables, 2C+E TPS, ELV extra low voltage alarm cable, 2C+E, TPS, and Power cable-3 core. The assessment includes the cables referenced in EN 1366-3:2009 and listed in Table 30.

Table 30 Cables for the standard configuration

Cable	Cable type	Group	Number of cables	Dimensions	Designation	Standard	Insulation / sheath material	Diameter range (mm)	Nominal weight (kg/km) ^a
A1	small sheathed	1	10	5 × 1,5 mm ²	see Annex H ^b	HD 603.3	PVC / PVC ^c	14 ^{a,d}	300 ^d
A2	small sheathed	1	10	5 × 1,5 mm ²	H07RN-F 5G1,5	HD 22.4	EPR / PO ^e	11,2 – 14,4 ^{a,f}	186 ^d
A3	small sheathed	1	10	5 × 1,5 mm ²	see Annex H ^b	HD 604.5	XLPE / EVA ^g	11,0 – 14,0 ^{a,h}	230 ^d
B	small sheathed	1	2	1 × 95 mm ²	see Annex H ^b	HD 603.3	PVC / PVC ^c	18 – 21 ^{a,i}	1150 ^d
C1	large sheathed	2	1	4 × 95 mm ²	see Annex H ^b	HD 603.3	PVC / PVC ^c	42 – 49 ^{a,i}	5300 ^d
C2	large sheathed	2	1	4 × 95 mm ²	H07RN-F 4G95	HD 22.4	EPR / PO ^e	48,4 – 61 ^{a,f}	5830 ^d
C3	large sheathed	2	1	4 × 95 mm ²	see Annex H ^b	HD 604.5	XLPE / EVA ^g	37,5 – 45,5 ^{a,h,j} 36 ^{a,h,k}	4050 ^d
D1	large sheathed	2	1	4 × 185 mm ²	see Annex H ^b	HD 603.3	PVC / PVC ^c	57 ^{a,d}	9900 ^d
D2	large sheathed	2	1	4 × 185 mm ²	H07RN-F 4G185	HD 22.4	EPR / PO ^e	64 – 80 ^{a,f}	9700 ^d
D3	large sheathed	2	1	4 × 185 mm ²	see Annex H ^b	HD 604.5	XLPE / EVA ^g	52,5 – 62,5 ^{a,h,j} 49 ^{a,h,k}	7750 ^d
E	large sheathed	2	2	1 × 185 mm ²	see Annex H ^b	HD 603.3	PVC / PVC ^c	24 – 28 ^{a,i}	2050 ^d
F	cable bundle (telecommunication cable)	3	1 tied bundle of 100 mm diameter ^l	20 × 2 × 0,6 mm screened ^m	see Annex H ^b	-	PE / PE ⁿ	15 to 17 ^{a,o,p}	275 to 320 ^{d,p}
G1	non-sheathed (wire)	4	1	1x95 mm ²	H07V-R	HD 21.3	PVC / - ^c	14.1 – 17.1 ^{a,q}	980 ^d
G2	non-sheathed (wire)	4	1	1x185 mm ²	H07V-R	HD 21.3	PVC / - ^c	19.3 – 23.3 ^{a,q}	1890 ^d

The vertical separating elements considered in this assessment are given below.

- Minimum 116 mm thick flexible or rigid walls
- Minimum 75 mm thick AAC walls or rigid walls
- The horizontal separating elements considered in this assessment are:
- Minimum 150 mm concrete slab
- Minimum 235 mm thick plasterboard ceiling system

7.2 Methodology

The method of assessment used is summarised in Table 31.

Table 31 Method of assessment

Assessment method	
Level of complexity	Complex assessment
Type of assessment	Qualitative

7.3 Assessment of various cables in minimum 90 mm flexible or rigid wall protected by BOSS FireMastic-HPE sealant

7.3.1 Proposed construction

Table 32 lists the proposed cables to be installed in a minimum 90 mm flexible or rigid wall and protected with BOSS FireMastic-HPE sealant. In test FSP1791, a bundle of cables was installed in an aperture in a 90 mm thick plasterboard wall system and protected with BOSS FireMastic-HPE sealant.

Table 32 Tested cables in flexible wall system

Cables	Reference test	Maximum aperture (mm)	Sealant configuration	FRL
Single core 5 mm OD NBN cable (OFS Optical cable)	FSP 1791 Specimen 5	8 mm	Surface seal around the cable with a 20 mm × 20 mm fillet of FireMastic-HPE intumescent sealant on the non-exposed side only.	-/60/60 Exposed from the non sealant side only
Single core 5 mm OD NBN cable (OFS Optical cable)	FSP 1791 Specimen 8	8 mm	Surface seal around the cable with a 20 mm × 20 mm fillet of FireMastic-HPE intumescent sealant on the exposed side only.	-/60/60 Exposed from the sealant side only
Bundle of 8 × 2.5 mm ² 3 core TPS cables	FSP 1791 Specimen 6	60 mm	Depth of the plasterboard and finished flush on both sides	-/60/60

7.3.2 Discussion

Assessment of different cable size

In test FSP 1791, specimens 5, and 8 consisted of a single core 5 mm OD NBN cable (OFS Optical cable), in specimen 5 the sealant was applied as surface seal around the cable with a 20 mm × 20 mm fillet of FireMastic-HPE intumescent sealant on the non-exposed side only, specimen 8 was the same but with the sealant applied on the opposite side (being the exposed side). An 8 mm annular gap between the service and the separating element was filled with BOSS FireMastic-HPE sealant to a depth of 13 mm and finished flush. Both services achieved an FRL of -/60/60.

Similarly, specimen 6, consisted of a Bundle of 8 × 2.5 mm² 3 core TPS cables installed within a 60 mm aperture. The annular gap between the services and the separating element filled with BOSS FireMastic-HPE to the depth of the plasterboard (13 mm) on both sides.

Based on the test results, a smaller bundle of cables (less number of cables and smaller core size) is positively assessed, provided that the annular gap size and sealant depth are kept as tested. Additionally, the cable configuration from specimens 5 and 8 as outlined above is assessed for an FRL -/60/60, regardless the direction of the exposure compared to the side that has the sealant applied to.

Assessment of various cables tested in Hebel wall

It is proposed to extend the use of services previously tested in Hebel wall system to minimum 90 mm thick flexible wall systems. To start with, the performance of BOSS FireMastic HPE sealant in flexible plasterboard wall systems was established through various tests of plastic, cable and insulated metal pipes. From an integrity perspective, the BOSS FireMastic HPE sealant is expected to expand and close off any gaps formed by the melted cable sheathing. Whereas, from an insulation perspective, the main mode of heat transfer is through the conduction of heat from the fire side to the non-fire side. As the proposed flexible wall system is thicker than the Hebel wall, it is reasonable to consider that the insulation performance will be similar to or better than the insulation achieved in the Hebel test. The proposed sealant configuration must include the application of the sealant to the full depth of the plasterboards on each side of the wall system.

Assessment of various cables in rigid wall system

In accordance with the provisions in AS 1530.4:2014, the results for the test with a plasterboard lined frame wall system would be applicable for similar penetration and sealing systems installed in a concrete or masonry wall of the same or greater thickness.

7.3.3 Conclusion

The technical review found that the cables protected by BOSS FireMastic-HPE sealant are expected to achieve the fire resistance levels (FRL) given in Table 33– in accordance with AS 1530.4:2014 and assessed in accordance with AS 4072.1:2005.

Table 33 Assessment outcome of cables in 90 mm flexible or rigid wall

Cables	Annular gap (mm)	Sealant configuration	FRL
Single core 5 mm OD NBN cable (OFS Optical cable)	8	Surface seal around the cable with a 20 mm × 20 mm fillet of FireMastic-HPE intumescent sealant on the non-exposed side only. Or Surface seal around the cable with a 20 mm × 20 mm fillet of FireMastic-HPE intumescent sealant on the exposed side only.	-/60/60
Bundle of 8 × 2.5 mm ² 3 core TPS cables	60 mm	Depth of the plasterboard and finished flush on both sides as shown in Figure 2	-/60/60

7.4 Assessment of various cables in minimum 116 mm flexible or rigid wall protected by BOSS FireMastic-HPE sealant

7.4.1 Proposed construction

Table 34 lists the proposed cables to be installed in a minimum 116 mm flexible or rigid wall and protected with BOSS FireMastic-HPE sealant. In test FRT180472.1, a bundle of cables was installed in an aperture in a 116 mm thick plasterboard wall system and protected with BOSS FireMastic-HPE sealant.

Table 34 Tested cables in flexible wall system

Cables	Reference test	Maximum aperture (mm)	Sealant configuration	FRL
Bundle of 8 × fire alarm cable.	FRT180472.1	70	Depth of the plasterboard and finished flush on both sides	-/120/120
2 × RG6 Coax cables 2 × CAT6 cables 2 × 4 Core security cables (7/0.20 mm)	FRT210322.1	40	20 mm deep both sides finished flush as shown in Figure 2	-/120/120
6 × 2.5 mm ² 2C+E TPS cables	FRT210322.1	57	25 mm deep both sides finished flush as shown in Figure 2	-/120/120
4 × ELV extra low voltage alarm cables (2 core round)	FRT210322.1	20	25 mm deep both sides finished flush as shown in Figure 2	-/120/90
1 × 16 mm ² 2C+E cable	FRT210322.1	40	20 mm deep both sides finished flush as shown in Figure 2	-/120/120
<ul style="list-style-type: none"> 3/8 + 5/8 FR paircoil with 9 mm non fire rated lagging- 0.8 mm / 1.0 mm thick 2.5 mm² 2C+E TPS cable 	FRT220141	80	25 mm deep finished with 20 mm×20 mm fillet on both sides	-/120/120
4 × 0.75 mm ² TBS fire alarm cables	FRT220141	30	25 mm deep both sides finished flush as shown in Figure 2	-/120/120

Cables	Reference test	Maximum aperture (mm)	Sealant configuration	FRL
Bundle of 22 × Power cable – 3 Core 2.5 mm ²	FRT180473	90	25 mm deep finished flush on both sides as shown in Figure 2	-/120/60
Bundle of 38 × CAT6 Data cables	FRT180473	90	25 mm deep finished flush on both sides as shown in Figure 2	-/120/60
<ul style="list-style-type: none"> Up to 10 A1 Up to 10 A2 Up to 10 A3 Up to 2 Cable B Up to 63 mm HDPE Pipe 	Chilt/RF12089A ARS	300 mm wide × 100 mm high	25 mm deep applied in the voids around cables and pipe	-/120/120

7.4.2 Discussion

Assessment of different cable size

In test FRT180472.1, service E, a 40 mm diameter bundle of 8 fire alarm cables was fitted in a 70 mm diameter aperture. A 15 mm annular gap between the service and the separating element was filled with BOSS FireMastic-HPE sealant to a depth of 26 mm and finished flush on both sides. The system achieved an FRL of -/120/120. Based on the test results, a smaller bundle of cables (less number of cables and smaller core size) is positively assessed, provided that the annular gap size and sealant depth are kept as tested.

Assessment of various cables tested in Hebel wall

It is proposed to extend the use of services previously tested in Hebel wall system to minimum 116 mm thick flexible wall systems. To start with, the performance of BOSS FireMastic HPE sealant in flexible plasterboard wall systems was established through various tests of plastic, cable and insulated metal pipes. From an integrity perspective, the BOSS FireMastic HPE sealant is expected to expand and close off any gaps formed by the melted cable sheathing. Whereas, from an insulation perspective, the main mode of heat transfer is through the conduction of heat from the fire side to the non-fire side. As the proposed flexible wall system is thicker than the Hebel wall, it is reasonable to consider that the insulation performance will be similar to or better than the insulation achieved in the Hebel test. The proposed sealant configuration must include the application of the sealant to the full depth of the plasterboards on each side of the wall system.

Assessment of various cables in rigid wall system

In accordance with the provisions in AS 1530.4:2014, the results for the test with a plasterboard lined frame wall system would be applicable for similar penetration and sealing systems installed in a concrete or masonry wall of the same or greater thickness.

7.4.3 Conclusion

The technical review found that the cables protected by BOSS FireMastic-HPE sealant are expected to achieve the fire resistance levels (FRL) given in Table 35 – in accordance with AS 1530.4:2014 and assessed in accordance with AS 4072.1:2005.

Table 35 Assessment outcome of cables in minimum 116 mm thick flexible wall or minimum 75 mm rigid wall

Cables	Aperture size (mm)	Sealant configuration	FRL
Bundle of Up to 8 × fire alarm cable.	70	Depth of the plasterboard and finished flush on both sides	-/120/120

Cables	Aperture size (mm)	Sealant configuration	FRL
Up to 2 × RG6 Coax cables Up to 2 × CAT6 cables Up to 2 × 4 Core security cables (7/0.20 mm) Up to 6 of any type of the above listed cables	40	20 mm deep both sides finished flush as shown in Figure 2	-/120/120
Up to 6 × 2.5 mm ² 2C+E TPS cables	57	25 mm deep both sides finished flush as shown in Figure 2	-/120/120
Up to 4 × ELV extra low voltage alarm cables (2 core round)	20	25 mm deep both sides finished flush as shown in Figure 2	-/120/90
Up to 1 × 16 mm ² 2C+E cable	40	20 mm deep both sides finished flush as shown in Figure 2	-/120/120
<ul style="list-style-type: none"> Up to 3/8 + 5/8 FR paircoil with 9 mm non fire rated lagging- 0.8 mm / 1.0 mm thick Up to 2.5 mm² 2C+E TPS cable 	80	25 mm finished with 20 mm×20 mm fillet on both sides	-/120/120
Up to 4 × 0.75 mm ² TBS fire alarm cable	30	25 mm deep finished flush on both sides as shown in Figure 2	-/120/120
Bundle of Up to 22 × Power cable – 3 Core 2.5 mm ²	90	25 mm deep finished flush on both sides as shown in Figure 2	-/120/60
Bundle of 38 × CAT6 Data cables	90	25 mm deep finished flush on both sides as shown in Figure 2	-/120/60
<ul style="list-style-type: none"> Up to 10 A1 Up to 10 A2 Up to 10 A3 Up to 2 Cable B Up to 63 mm HDPE Pipe 	300 mm wide × 100 mm high	25 mm deep applied in the voids around cables and pipe	-/120/120

7.5 Assessment of various cables in minimum 75 mm rigid wall protected by BOSS FireMastic-HPE sealant

7.5.1 Proposed construction

Table 36 lists the tested cables in FRT210322.1, FRT220141 and FRT180473 in accordance with AS 1530.4:2014.

In test FRT210322.1, the tested system included 75 mm thick AAC wall system penetrated with 18 services protected with BOSS FireMastic-HPE sealant.

In test FRT220141 R1.1, the tested system included 75 mm thick AAC wall system penetrated with 9 services protected with BOSS FireMastic-HPE sealant.

In test FRT180473.1, the tested system included 75 mm thick Hebel Power Panel penetrated with 13 services protected with BOSS FireMastic-HPE sealant.

Table 36 Tested cables in rigid wall system

Cables	Reference test	Maximum aperture (mm)	Sealant configuration	FRL
2 × RG6 Coax cables 2 × CAT6 cables 2 × 4 Core security cables (7/0.20 mm)	FRT210322.1	40 mm	20 mm deep both sides finished flush as shown in Figure 3	-/120/120
6 × 2.5 mm ² 2C+E TPS cables	FRT210322.1	57 mm	25 mm deep both sides finished flush as shown in Figure 3	-/120/120
4 × ELV extra low voltage alarm cables (2 core round)	FRT210322.1	20 mm	25 mm deep both sides finished flush as shown in Figure 3	-/120/90
1 × 16 mm ² 2C+E cable	FRT210322.1	40 mm	20 mm deep both sides finished flush as shown in Figure 3	-/120/120
3/8 + 5/8 FR paircoil with 9 mm non fire rated lagging- 0.8 mm / 1.0 mm thick 2.5 mm ² 2C+E TPS cable	FRT220141	80 mm	25 mm deep finished with 20 mm × 20 mm fillet on both sides	-/120/120
4 × 0.75 mm ² TBS fire alarm cable	FRT220141	30 mm	25 mm deep finished flush on both sides as shown in Figure 3	-/120/120
Bundle of 22 × Power cable – 3 Core 2.5 mm ²	FRT180473	90 mm	25 mm deep finished flush on both sides as shown in Figure 3	-/120/60
Bundle of 38 × CAT6 Data cable – DN50 mm	FRT180473	90 mm	25 mm deep finished flush on both sides as shown in Figure 3	-/120/60

7.5.2 Discussion

Improvements of insulation performance

Most of the services listed in Table 36 achieved an FRL of -/120/120. However, some cables failed to maintain their insulation performance for up to 120 minutes. In FRT210322.1, specimen N, 4 × ELV extra low voltage alarm cables (2 core round) were installed in a 20 mm diameter aperture. The cables were protected by BOSS FireMastic-HPE sealant, filled in the annular gap between the services and the separating element to a depth of 25 mm with PE backing rod support, and finished flush to the surface on both the exposed and unexposed sides of the separating element. At 111 minutes, the thermocouple positioned on the Hebel wall recorded a temperature of 206 C°. The wall used in the test was single mesh. It is expected that, if the service is installed in a double mesh Hebel wall with an FRL of -/120/120, the FRL will be maintained.

In the reference test FRT180473.1, specimen A, an aperture of 90 mm diameter was made in 75 mm thick AAC wall system. The opening was penetrated with a bundle of 22 × power cable – 3 Core 2.5 mm². The cables were protected by BOSS FireMastic-HPE sealant, applied to a depth of 25 mm and finished flush on both sides. The service penetration performed 121 minutes in integrity and 68 minutes in insulation. The test data showed that the temperature – recorded by the thermocouple positioned on the wall at 25 mm away from the service – reached 200 C° at 68 minutes. The system is positively assessed to an FRL of -/120/120 if the wall is locally built up with a 13 mm fire rated plasterboard and the sealant is extended to the full depth of the additional plasterboard.

In test FRT180473.1, specimen H, an aperture of 90 mm diameter was made in a 75 mm thick AAC wall system. The opening was penetrated with a bundle of 38 × CAT6 Data cables – DN50 mm. The cables were protected by BOSS FireMastic-HPE sealant, applied to a depth of 25 mm and finished flush on both sides. The service penetration performed 121 minutes in integrity and 69 minutes in insulation as the temperature recorded by the thermocouple placed on the wall at 25 mm from the service reached 180 C° more than the ambient temperature. The system is positively assessed to an FRL of -/120/120 if the wall is locally built up with a 13 mm fire rated plasterboard and the sealant is extended to the full depth of the additional plasterboard.

Optional installation of cables in conduits

In test FRT210330, a 32 mm diameter conduit filled with TPS cables was inserted into a 130 mm thick CLT wall system through an aperture of 70 mm diameter. The annular gap was filled with BOSS FireMastic-HPE sealant to a depth of 20 mm and finished flush with the wall. When tested, the specimen did not fail and achieved an FRL of -/90/90. It is considered that CLT as a timber-based product is more onerous than a gypsum-based product because the CLT chars when it is exposed to elevated temperatures. Therefore, it is expected that, if the conduit is installed in a minimum 75 mm AAC wall, it will perform at least similarly to tested conduit in a CLT wall. Hence, it is positively assessed.

7.5.3 Conclusion

The technical review found that the cables protected by BOSS FireMastic-HPE sealant are expected to achieve the fire resistance levels (FRL) given in Table 37 – in accordance with AS 1530.4:2014 and assessed in accordance with AS 4072.1:2005.

Table 37 Assessment outcome of cables in 75 mm thick rigid wall system

Cables	Maximum aperture (mm)	Sealant configuration	FRL
<ul style="list-style-type: none"> Up to 2 × RG6 Coax cables Up to 2 × CAT6 cables Up to 2 × 4 Core security cables (7/0.20 mm) 	40 mm	20 mm deep both sides finished flush as shown in Figure 3	-/120/120
Up to 6 × 2.5 mm ² 2C+E TPS cables	57 mm	25 mm deep both sides finished flush as shown in Figure 3	-/120/120
Up to 4 × ELV extra low voltage alarm cables (2 core round)	20 mm	25 mm deep both sides finished flush as shown in Figure 3	-/120/120
Up to 1 × 16 mm ² 2C+E cable	40 mm	20 mm deep both sides finished flush as shown in Figure 3	-/120/120
<ul style="list-style-type: none"> Up to 3/8 + 5/8 FR paircoil with 9mm non fire rated lagging- 0.8mm / 1.0 mm thick Up to 2.5 mm² 2C+E TPS cable 	80 mm	25 mm deep finished with 20 mm × 20 mm fillet on both sides	-/120/120
Up to 4 × 0.75 mm ² TPS cable	30 mm	25 mm deep finished flush on both sides as shown in Figure 3	-/120/120
Bundle of Up to 22 × Power cable – 3 Core 2.5 mm ²	90 mm	Full depth of the wall and finished flush on both sides. Additionally, a build-up of 13 mm thick fire rated plasterboard required locally around the service.	-/120/120
Bundle of Up to 22 × Power cable – 3 Core 2.5 mm ²	90 mm	Full depth of the wall and finished with 25 mm × 25 mm fillet on both sides.	-/90/90
Bundle of Up to 38 × CAT6 Data cable – DN50 mm	90 mm	Full depth of the wall and finished flush on both sides. Additionally, a build-up of 13 mm thick fire rated plasterboard required locally around the service.	-/120/120
Bundle of Up to 38 × CAT6 Data cable – DN50 mm	90 mm	Full depth of the wall and finished with 25 mm × 25 mm fillet on both sides.	-/90/90
Bundle of Up to 38 × CAT6 Data cable – DN50 mm	90 mm	Full depth of the wall and finished flush on both sides.	-/120/60

Cables	Maximum aperture (mm)	Sealant configuration	FRL
Up to 32 mm conduit Up to 1.9 mm thick Up to 8 2.5 mm ² 2C+E TPS cables inside 32 mm conduit	70 mm	20 mm deep both finished flush	-/90/90

7.6 Assessment of various cables in minimum 235 mm plasterboard ceiling system protected by BOSS FireMastic-HPE sealant

7.6.1 Proposed construction

Table 38 lists the tested cables in FRT180474.3 in accordance with AS 1530.4:2014.

In the reference test FRT180474.3, a 235 mm thick ceiling system was penetrated with 10 services and protected with various local fire stopping protections. The ceiling consisted of 2 layers of 13 mm fire-rated plasterboard was fixed directly onto the timber framing on the exposed side using plasterboard screws at nominal 150 mm centres on the joist and 100 mm centres on the perimeter framing. On the unexposed side, particleboard flooring was fixed directly onto the timber framing. The sealant used in the ceiling system was BOSS FireMastic-HPE sealant, and the sealant used in the timber flooring system was BOSS FireMastic-300. This section will discuss the cable penetrations protected by BOSS FireMastic-HPE sealant only.

Table 38 Tested cables in ceiling system

Cables	Reference test	Maximum aperture (mm)	Sealant configuration	FRL
4 × TPS – 2.5 mm ² 2C+E cables	FRT180474.3	44	BOSS FireMastic – HPE – On the interface between the service and the fire-rated plasterboard to the full depth of the plasterboard on the exposed side and finished flush with the surface. BOSS FireMastic-300 – On the interface between the service and the particleboard flooring to the full depth of the particleboard flooring on the unexposed side and finished flush with the surface.	-/90/90
Up to 2 × 25 mm UPVC conduit – 2 mm wall thickness Up to 2.5 mm ² 2C+E TPS cables (Up to QTY 2)	FRT180474.3	51	BOSS FireMastic HPE – On the interface between the fire collar and the service to the depth of the fire collar and finished flush with the fire collar. BOSS FireMastic 300- On the interface between the service and particleboard flooring to the depth of the particleboard flooring on the unexposed side and finished flush with the surface	-/90/90

7.6.2 Discussion

Assessment of various cable sizes

It is proposed to extend the achieved FRL to cover TPS cables up to a bundle of 4 cables provided the annular gap and the sealant configuration is maintained. In test FRT180474.3, 4 × TPS – 2.5 mm², 2C+E cables were fitted through a 44 mm diameter aperture made in a ceiling system. The ceiling consisted of 2 layers of 13 mm fire-rated plasterboard. BOSS FireMastic-HPE sealant was applied to the depth of 26 mm on the exposed side and finished flush with the surface. On the unexposed side,

a particleboard flooring was fixed directly onto the timber framing. The gap between the service and the separating element was filled with FireMastic-300 sealant to the full depth of the particleboard flooring and finished flush with the surface. The service maintained the integrity and insulation for the whole 90 minutes duration of the test. However, the RISF thermocouple that was placed on the service at 25 mm from the aperture failed at 55 minutes. As the tested specimen included a bundle of the maximum 4 TPS cables, it is reasonable to consider that a single TPS cable up to a bundle of 4 are expected to maintain the integrity and insulation for at least more than 90 minutes in accordance with AS 1530.4:2014.

7.6.3 Conclusion

The technical review found that the cables protected by BOSS FireMastic-HPE sealant are expected to achieve the fire resistance levels (FRL) given in Table 39 – in accordance with AS 1530.4:2014 and assessed in accordance with AS 4072.1:2005.

Table 39 Assessment outcome of cables in ceiling system

Cables	Maximum aperture (mm)	Sealant configuration	FRL	RISF
Up to 4 × TPS – 2.5 mm ² 2C+E cables	44	BOSS FireMastic – HPE – On the interface between the service and the fire-rated plasterboard to the full depth of the plasterboard on the exposed side and finished flush with the surface. BOSS FireMastic-300 or BOSS FireMastic – HPE – On the interface between the service and the particleboard flooring to the full depth of the particleboard flooring on the unexposed side and finished flush with the surface.	-/90/90	Failure at 55 minutes
Up to 2 × 25 mm UPVC conduit – 2 mm wall thickness Up to 2.5 mm ² 2C+E TPS cables (Up to QTY 2)	51	BOSS FireMastic HPE – On the interface between the fire collar and the service to the depth of the fire collar and finished flush with the fire collar. BOSS FireMastic 300- On the interface between the service and particleboard flooring to the depth of the particleboard flooring on the unexposed side and finished flush with the surface	-/90/90	Failure at 24 minutes

7.7 Assessment of various cables in minimum 150 mm thick AAC floor system protected by BOSS FireMastic-HPE sealant

7.7.1 Proposed construction

Table 40 lists the cables tested in WARRES 342025, WARRES 359904 FR and WARRES 342026 in accordance with BS EN 1366-3:2009.

In the reference test WARRES 342025, a 150 mm thick AAC floor system was provided with five 200 mm by 200 mm apertures and one 50 mm by 50 mm aperture, each penetrated with various cables and services. The floor was also provided with four circular apertures, each penetrated by a range of insulated steel and copper pipes. In this section, the cables protected with a sealant identical to BOSS FireMastic-HPE sealant will be discussed.

In test WARRES 342026, the tested floor had a dimension of 2230 mm long by 1740 mm wide by 150 mm thick and was provided with ten circular apertures of varying sizes penetrated with various services. In this section, the cables protected with a sealant identical to BOSS FireMastic-HPE sealant will be considered.

In test WARRES 359904 FR, a 1100 mm high by 750 mm wide aperture was sealed with a double layer of 50 mm thick “BOSS Fire Batt”. The batt was coated on both faces with ablative coating. Each

horizontal and vertical cut of the batt to each substrate was sealed with a sealant identical to Boss FireMastic 300. The services penetrated the batt were sealed with BOSS FireMastic-HPE sealant.

Table 40 Tested cables in AAC floor system

Cables	Reference test	Maximum aperture (mm)	Sealant configuration	Fire resistance performance	
Steel cable tray supporting 10 "A1", 10 "A2", ten "A3", two "B", one "C1", one "C2" and one "C3" cables	WARRES 359904 FR	500 mm wide with 20 mm annular space above cables and tray	25 mm deep HPE to both faces and Firemastic 300 coatback 300 mm along the cable on the unexposed face. 500 mm wide with 20 mm annular space above cables and tray.	500 mm perforated tray	Integrity: 120 min Insulation: 120 min
				A1	Integrity: 120 min Insulation: 120 min
				A2	Integrity: 120 min Insulation: 90 min
				A3	Integrity: 120 min Insulation: 120 min
				B	Integrity: 120 min Insulation: 120 min
				C1	Integrity: 120 min Insulation: 120 min
				C2	Integrity: 120 min Insulation: 70 min
				C3	Integrity: 120 min Insulation: 120 min
C1, C2 and C3 type electric cable	WF 342025	200 mm × 200 mm	25 mm deep finished flush with the upper face of the floor and included a 100 mm deep infill of friction fitted stone wool insulation	Integrity: 180 min Insulation: 30 min	
D1, D2 and D3 type electric cable	WF 342025	200 mm × 200 mm	25 mm deep finished flush with the upper face of the floor and included a 100 mm deep infill of friction fitted stone wool insulation	Integrity: 120 min Insulation: 30 min	

Cables	Reference test	Maximum aperture (mm)	Sealant configuration	Fire resistance performance
A1, A2 and A3 type electric cable.	WF 342025	200 mm × 200 mm	25 mm deep finished flush with the upper face of the floor and included a 100 mm deep infill of friction fitted stone wool insulation	Integrity: 180 min Insulation: 30 min
Telecom cables	WF 342026	200 mm × 200 mm	25 mm depth finished flush on both sides. Included 100 mm deep infill friction fitted stone wool insulation	Integrity: 240 min Insulation: 45 min
Bundle of F type size (20 2 0.6 mm ²)	WARRES 342026	200 mm × 200 mm	25 mm depth finished flush on both sides. Included 100 mm deep infill friction fitted stone wool insulation	Integrity: 240 min Insulation: 30 min
Perforated steel cable tray	WF 342025	200 mm × 200 mm	25 mm depth finished flush on both sides. Included 100 mm deep infill friction fitted stone wool insulation	Integrity: 120 min Insulation: 30 min
One G1 and one G2 type electric cable	WF 342025	200 mm × 200 mm	25 mm depth finished flush on both sides. Included 100 mm deep infill friction fitted stone wool insulation	Integrity: 180 min Insulation: 0 min
One E type electric cable	WF 342025	50 mm × 50 mm	25 mm depth finished flush on both sides. Included 100 mm deep infill friction fitted stone wool insulation	Integrity: 240 min Insulation: 0 min
PE conduit filled with electric cables; three "A1", three "A2", three "A3", one "B" cables	WF 342026	60 mm	25 mm depth finished flush on both sides. Included 100 mm deep infill friction fitted stone wool insulation	Integrity: 120 min Insulation: 90 min

7.7.2 Discussion

Improvements of insulation performance

The services listed in Table 40 failed insulation at different times. It is proposed to improve the service insulation performance. In order to mitigate the expected temperature increase on the non-fire side, the services must be wrapped with P40-MAK wrap for a length of 600 mm from the separating element on either side. Accordingly, the insulation performance can be extended to 120 minutes.

Assessment of various cable sizes

In the reference test WARRES 342025, service B, a 200 mm × 200 mm aperture was made in a 150 mm thick AAC floor. The aperture was penetrated with electric cable types D1, D2 and D3. The services were protected with a sealant identical to BOSS FireMastic-HPE sealant. The sealant was applied to 25 mm deep, finished flush with the upper face of the floor and included a 100 mm deep infill of friction fitted stone wool insulation. The service failed integrity at 122 minutes, as the whole service had gone up in flames. The service failed insulation at 42 minutes due to a recorded temperature increase to 200 C° on the unexposed side.

Service C, electric cable types A1, A2 and A3. The services were protected with a sealant identical to BOSS FireMastic-HPE sealant. The sealant was applied to 25 mm deep and finished flush with the upper face of the floor and included a 100 mm deep infill of friction fitted stone wool insulation. The service failed integrity at 212 minutes as flames emitted through the char material of the seal. The service failed insulation at 40 minutes due to a recorded temperature increase to 200 C° on the unexposed side.

It is proposed to assess the cable penetrations of sizes equal to or smaller than the tested size. The positive aspect of assessing smaller cables lies in the fact that they are expected to exhibit improved fire resistance characteristics compared to larger cables. The reduced size of the conductors decreases the potential for heat conduction through the cables, limiting the spread of heat and flames from the exposed side to the unexposed side. Therefore, the assessment of smaller cables is positive, provided that the size of the annular gap and the sealant configuration are maintained as tested.

7.7.3 Conclusion

The technical review found that the cables protected by BOSS FireMastic-HPE sealant are expected to achieve the fire resistance levels (FRL) given in Table 41 – in accordance with AS 1530.4:2014 and assessed in accordance with AS 4072.1:2005.

Table 41 Assessment outcome of cables in min 150 mm thick AAC floor

Cables	Maximum aperture (mm)	Sealant configuration	FRL	
Steel cable tray supporting up to 10 "A1", 10 "A2", ten "A3", two "B", one "C1", one "C2" and one "C3" cables	500 mm wide with 20 mm annular space above cables and tray	25 mm deep HPE to both faces and Firemastic 300 coatback 300 mm along the cable on the unexposed face.	500 mm perforated tray	-/120/120
			A1	-/120/120
		500 mm wide with 20 mm annular space above cables and tray.	A2	-/120/90
			A3	-/120/120
			B	-/120/120
			C1	-/120/120
			C2	-/120/120
			C3	-/120/120
C1, C2 and C3 type electric cable	200 mm × 200 mm	25 mm deep finished flush with the upper face of the floor and included a 100 mm deep infill of friction fitted stone wool insulation. 600 mm long P40-MAK wrap to be installed on both sides.	-/180/120	
D1, D2 and D3 type electric cable	200 mm × 200 mm	25 mm deep finished flush with the upper face of the floor and included a 100 mm deep infill of friction fitted stone wool insulation. 600 mm long P40-MAK wrap to be installed on both sides.	-/120/120	

Cables	Maximum aperture (mm)	Sealant configuration	FRL
A1, A2 and A3 type electric cable.	200 mm × 200 mm	25 mm deep finished flush with the pper face of the floor and included a 100 mm deep infill of friction fitted stone wool insulation. 600 mm long P40-MAK wrap to be installed on both sides.	-/180/120
Telecom cables	200 mm × 200 mm	25 mm depth finished flush on both sides. Included 100 mm deep infill friction fitted stone wool insulation. 600 mm long P40-MAK wrap to be installed on both sides.	-/240/120
Bundle of F type size (20 2 0.6 mm ²)	200 mm × 200 mm	25 mm depth finished flush on both sides. Included 100 mm deep infill friction fitted stone wool insulation.	-/240/30
Perforated steel cable tray	200 mm × 200 mm	25 mm depth finished flush on both sides. Included 100 mm deep infill friction fitted stone wool insulation. 600 mm long P40-MAK wrap to be installed on both sides.	-/120/120
One G1 and one G2 type electric cable	200 mm × 200 mm	25 mm depth finished flush on both sides. Included 100 mm deep infill friction fitted stone wool insulation. 600 mm long P40-MAK wrap to be installed on both sides.	-/180/120
One E type electric cable	50 mm× 50 mm	25 mm depth finished flush on both sides. Included 100 mm deep infill friction fitted stone wool insulation. 600 mm long P40-MAK wrap to be installed on both sides.	-/240/120
PE conduit filled with electric cables; up to three "A1", three "A2", three "A3", one "B" cables	250 mm × 250 mm	25 mm depth finished flush on both sides. Included 100 mm deep infill friction fitted stone wool insulation	-/120/90

7.8 Assessment of various cables in minimum 150 mm concrete slab system protected by BOSS FireMastic-HPE sealant

7.8.1 Proposed construction

Table 42 lists the cables tested in FRT220049, in accordance with AS 1530.4:2014.

In the reference test FRT220049, a 150 mm concrete floor system was tested. The slab was penetrated by 10 different services. The services were protected with various fire stopping protections. This section discusses the cable penetration protected with BOSS FireMastic-HPE sealant.

Table 42 Tested cables in concrete floor

Cables	Reference test	Maximum aperture (mm)	Sealant configuration	FRL
6 × 2.5 mm ² TPS cable	FRT220049	30	25 mm - Both sides with backing rod Finished flush	-/240/240
<ul style="list-style-type: none"> • 4 x RG6 Coax cables • 4 x CAT 6 cables • 2 x Fire alarm cables • Security cable 	FRT220049	50	25 mm - Both sides with backing rod Finished flush	-/240/240

7.8.2 Discussion

Assessment of various cable sizes

In the referenced test FRT220049, specimen F, a 6 × 2.5 mm² TPS cable was installed in a 30 mm dia. aperture size in 150 mm thick concrete floor slab. The annular gap was filled with BOSS FireMastic-HPE sealant to a depth of 25 mm with backing rods from both sides and finished flush. The system performed for up to 240 minutes integrity and insulation. It is proposed to assess a smaller size of the same cable. It is expected that smaller cables have smaller conductors which will reduce the amount of heat transfer to the unexposed side and hence it is less onerous. Therefore, the TPS cable sizes up to 6 × 2.5 mm² are positively assessed provided that the size of the annular gap and the sealant configuration are maintained as tested.

In test FRT220049, specimen G, four types of cables namely 4 × RG6 Coax cables, 4 × CAT 6 cables, 2 × Fire alarm cables, security cables were fitted into a 150 mm thick concrete floor system. The annular gap was filled with BOSS FireMastic-HPE sealant to the depth of 25 mm with backing rod from both sides and finished flush. The system performed up to 240 minutes integrity and insulation. It is proposed to assess a smaller size of the same cable which is positively assessed as discussed in section 7.7.2.

Assessment of cables tested in minimum 150 mm AAC floor

It is expected that the services tested in 150 mm thick AAC floor will behave similarly or better when installed in 150 mm thick concrete floor. Therefore, services in section 7.7 are positively assessed if installed in 150 mm thick concrete floor.

7.8.3 Conclusion

The technical review found that the cables protected by BOSS FireMastic-HPE sealant are expected to achieve the fire resistance levels (FRL) given in Table 43 – in accordance with AS 1530.4:2014 and assessed in accordance with AS 4072.1:2005.

Table 43 Assessment outcome of cables in concrete floor

Cables	Maximum aperture (mm)	Sealant configuration	FRL
Up to 6 × 2.5 mm ² TPS cable	30	25 mm - Both sides with backing rod Finished flush - Figure 11	-/240/240
<ul style="list-style-type: none"> • Up to 4 x RG6 Coax cables • Up to 4 x CAT 6 cables • Up to 2 x Fire alarm cables • Up to Security cable 	50	25 mm - Both sides with backing rod Finished flush	-/240/240

Cables	Maximum aperture (mm)	Sealant configuration	FRL
C1, C2 and C3 type electric cable	200 × 200	25 mm deep finished flush with the upper face of the floor and included a 100 mm deep infill of friction fitted stone wool insulation	-/180/120
D1, D2 and D3 type electric cable	200 × 200	25 mm deep finished flush with the upper face of the floor and included a 100 mm deep infill of friction fitted stone wool insulation	-/120/120
A1, A2 and A3 type electric cable.	200 × 200	25 mm deep finished flush with the upper face of the floor and included a 100 mm deep infill of friction fitted stone wool insulation	-/180/120
Telecom cables	200 × 200	25 mm depth finished flush on both sides. Included 100 mm deep infill friction fitted stone wool insulation	-/240/120
Perforated steel cable tray	200 × 200	25 mm depth finished flush on both sides. Included 100 mm deep infill friction fitted stone wool insulation	-/120/120
One G1 and one G2 type electric cable	200 × 200	25 mm depth finished flush on both sides. Included 100 mm deep infill friction fitted stone wool insulation	-/180/120
One E type electric cable	50 × 50	25 mm depth finished flush on both sides. Included 100 mm deep infill friction fitted stone wool insulation	-/240/120

7.9 Assessment of various cables in minimum 130 mm CLT wall system protected by BOSS FireMastic-HPE sealant

7.9.1 Proposed construction

Table 44 lists the cables tested in FRT 210330 in accordance with AS 1530.4:2014.

In test FRT 210330, the tested system included a 130 mm thick CLT wall system penetrated with 9 services. The combustible pipes protected with BOSS FireMastic-HPE sealant are considered in this section.

Table 44 Tested cables in CLT wall system

Services	Reference test	Maximum aperture (mm)	Sealant configuration	FRL
<ul style="list-style-type: none"> 32 mm conduit - 1.9 mm thick 6 × 2.5mm² 2C+E TPS cables inside 32 mm conduit 	FRT210330	70 mm	20 mm deep both finished flush	-/90/90
16mm ² 3C+E cable	FRT210330	40 mm	20 mm deep both finished flush	-/90/90
<ul style="list-style-type: none"> 2 × CAT 6 cable 2 × RG6 Coax cable Security cable 1 × Fig 8 cable 2 × Fire alarm cables 	FRT210330	40 mm	20 mm deep both finished flush	-/90/90

7.9.2 Discussion

Assessment of various cable sizes

In test FRT210330, specimen I, HVAC services, consists of 32 mm conduit - 1.9 mm thick, and 8 × 2.5 mm² 2C+E TPS cables inside the 32 mm conduit, placed in a 70 mm diameter aperture. The annular gap between the service and the separating element was filled with BOSS FireMastic-HPE sealant to a depth of 20 mm on both exposed and unexposed sides and finished flush with the wall. The test data showed that the temperature recorded by the thermocouple positioned on the service experienced an increase in temperature to approximately 150C° then started to reduce, which indicates closing off the gaps by the sealant. HVAC services-maintained integrity and insulation for 100 minutes.

Specimen C and Specimen D, which are 16 mm² 3C+E cable and a bundle of cables were inserted in two 40 mm diameter apertures, and the annular gaps were filled with BOSS FireMastic-HPE sealant to a depth of 20 mm and finished flush. The two services performed up to 90 minutes integrity and 90 minutes insulation. The test data showed that the recorded temperature was low, which indicates that the sealant was able to close off the gap formed when the cable sheathing or the conduit started to melt.

It is proposed to assess the cable penetrations of sizes equal to or smaller than those tested. It is expected that smaller cables will have smaller conductors, which will reduce the amount of heat transfer to the unexposed side and hence make it less onerous. Therefore, the assessment of smaller cables is positive, provided that the size of the annular gap and the sealant configuration are maintained as tested.

7.9.3 Conclusion

The technical review found that the cables protected by BOSS FireMastic-HPE sealant are expected to achieve the fire resistance levels (FRL) given in Table 51– in accordance with AS 1530.4:2014 and assessed in accordance with AS 4072.1:2005.

Table 45 Assessment outcome of cables in CLT wall system

Services	Reference test	Maximum aperture (mm)	Sealant configuration	FRL
<ul style="list-style-type: none"> 32 mm conduit - 1.9 mm thick 6 × 2.5mm² 2C+E TPS cables inside 32 mm conduit 	FRT210330	70 mm	20 mm deep both finished flush	-/90/90
Up to 16mm ² 3C+E cable	FRT210330	40 mm	20 mm deep both finished flush	-/90/90
<ul style="list-style-type: none"> 2 × CAT 6 cable 2 × RG6 Coax cable Security cable 1 × Fig 8 cable 2 × Fire alarm cables 	FRT210330	40 mm	20 mm deep both finished flush	-/90/90

7.10 Assessment of various cables in minimum 150 mm thick autoclaved blockwork wall system protected with BOSS FireMastic–HPE sealant

7.11 Proposed construction

Table 46 lists the cables tested in WF 371239 in accordance with EN1366.3:2009.

In test WF 371239, a 150 mm thick autoclaved blockwork wall system was tested with one blank seal and six services. The services are different types of cables protected with BOSS FireMastic – HPE sealant.

Table 46 Tested blank seal / cables in minimum 150 mm thick autoclaved blockwork wall

Services	Reference test	Maximum aperture (mm)	Sealant configuration	FRL
Blank seal	WF 371239	180 mm × 180 mm	The apertures were sealed using a 25 mm depth of Pyropro HPE sealant. The sealant was applied flush to both sides of the wall with a backing of 20 mm thick Rockwool RWA45 insulation with a measured density of 47.5 kg/m ³ .	Integrity: 240 min Insulation: 240 min
One C1, One C2, One C3 (each 4 × 95 mm ²), and one E (1 × 185 mm ²) cables.		180 mm × 180 mm		Integrity: 240 min Insulation: 95 min
One D1, One D2, One D3 (each 4 × 185 mm ²) cables.		180 mm × 180 mm		Integrity: 240 min Insulation: 111 min
Three A1, three A2, three A3 (each 5 × 1.5 mm ²), and one B (1 × 95 mm ²) cables.		180 mm × 180 mm		Integrity: 234 min Insulation: 49 min
Bundle of F (20 × 2 × 0.6 mm ²) telecom cables, two rigid H copper conduits (15 mm diameter 1 mm wall thickness), and two PVC conduits (16 mm diameter 2 mm wall thickness).		180 mm × 180 mm		Integrity: 240 min Insulation: 51 min
One G1 (1 × 95 mm ²) and one G2 (1 × 185 mm ²) cables.		180 mm × 180 mm		Integrity: 240 min Insulation: 67 min
One E (1 × 185 mm ²) cables.		50 mm × 50 mm		Integrity: 240 min Insulation: 64 min

7.11.1 Discussion

Assessment of various cable sizes

It is proposed to assess the cable penetrations of sizes equal to or smaller than those tested. It is expected that smaller cables will have smaller conductors, which will reduce the amount of heat transfer to the unexposed side and hence make it less onerous. Therefore, the assessment of smaller cables is positive, provided that the size of the annular gap and the sealant configuration are maintained as tested.

7.11.2 Conclusion

The technical review found that the cables protected by BOSS FireMastic-HPE sealant are expected to achieve the fire resistance levels (FRL) given in Table 47– in accordance with AS 1530.4:2014 and assessed in accordance with AS 4072.1:2005.

Table 47 Assessment outcome of cables in minimum 150 mm thick autoclaved blockwork wall

Services	Reference test	Maximum aperture (mm)	Sealant configuration	FRL
Blank seal	WF 371239	180 mm × 180 mm	The apertures were sealed using a 25 mm depth of Pyropro HPE sealant. The sealant was applied flush to both sides of the wall with a backing of 20 mm thick Rockwool RWA45 insulation with a measured density of 47.5 kg/m ³ .	Integrity: 240 min Insulation: 240 min
One C1, One C2, One C3 (each 4 × 95 mm ²), and one E (1 × 185 mm ²) cables.		180 mm × 180 mm		Integrity: 240 min Insulation: 95 min
One D1, One D2, One D3 (each 4 × 185 mm ²) cables.		180 mm × 180 mm		Integrity: 240 min Insulation: 111 min
Three A1, three A2, three A3 (each 5 × 1.5 mm ²), and one B (1 × 95 mm ²) cables.		180 mm × 180 mm		Integrity: 234 min Insulation: 49 min
Bundle of F (20 × 2 × 0.6 mm ²) telecom cables, two rigid H copper conduits (15 mm diameter 1 mm wall thickness), and two PVC conduits (16 mm diameter 2 mm wall thickness).		180 mm × 180 mm		Integrity: 240 min Insulation: 51 min
One G1 (1 × 95 mm ²) and one G2 (1 × 185 mm ²) cables.		180 mm × 180 mm		Integrity: 240 min Insulation: 67 min
One E (1 × 185 mm ²) cables.		50 mm × 50 mm		Integrity: 240 min Insulation: 64 min

8. Assessment of various HVAC bundle with or without cables protected with BOSS FireMastic–HPE sealant

8.1 Description of variation

HVAC service is a combination of pipes, paircoils and cables services used in Heating, Ventilation and Air Conditioning.

The vertical separating elements considered in this assessment are as given below.

- Minimum 90 mm flexible wall system
- Minimum 116 mm flexible wall system
- Minimum 75 mm thick AAC walls or rigid walls
- Minimum 130 mm thick CLT timber wall

The horizontal separating elements considered in this assessment are:

- Minimum 150 mm concrete slab
- Minimum 235 mm thick plasterboard ceiling system

8.2 Methodology

The method of assessment used is summarised in Table 48.

Table 48 Method of assessment

Assessment method	
Level of complexity	Complex assessment
Type of assessment	Qualitative

8.3 Assessment of various HVAC bundle with or without cables in minimum 90 mm flexible wall system protected by BOSS FireMastic-HPE sealant

8.3.1 Proposed construction

Table 51 lists the HVAC services tested in test reports FSP 1791 and EWFA 37995200.3.

In test FSP 1791, a 90 mm thick steel stud/plasterboard clad partition was tested accordance with AS 1530.4:214. The supporting construction was penetrated with nine service penetrations. The penetrations were sealed with BOSS FireMastic-HPE sealant. In this section, the HVAC services protected by BOSS FireMastic-HPE sealant are discussed.

In test EWFA 37995200.3. a 90 mm thick plasterboard wall system was penetrated by various services and protected with various BOSS products. In this section, the HVAC services protected with BOSS FireMastic-HPE sealant are discussed.

In test 2891600b.3, a 90 mm thick plasterboard wall system was penetrated by various services and protected with various sealants. In this section, the HVAC services protected with BOSS FireMastic-HPE sealant are discussed.

Table 49 Tested HVAC bundle with or without cables in 90 mm flexible wall system

Cables	Reference test	Maximum aperture (mm)	Sealant configuration	FRL
Paircoil 10 mm/15 mm insulated copper pipes with non-rated insulation lagging 2.5-mm ² 2C+E TPS power cable, and a 1.5 mm ² 2-core data cable 20 mm uPVC outlet pipe.	FSP 1791 - Specimen 3	80 mm	A second layer of 13 mm fire rated plasterboard 150 mm × 150 mm was placed over the penetration (on both sides) and secured to the wall. The edges of the plasterboard build up was coated with a 13 mm × 13 mm fillet of BOSS FireMastic-300 sealant. The resulting annular gap around the bunch sealed on both sides of the wall with FireMastic-HPE sealant to a nominal depth of 26 mm and finished flush with the wall.	-/60/60
Paircoil 10 mm/15 mm insulated copper pipes with non-rated insulation lagging 2.5-mm ² 2C+E TPS power cable, and a 1.5 mm ² 2-core data cable	FSP 1791 - Specimen 4	80 mm	On both sides of the wall BOSS MaxiCollar was surface mounted to the plasterboard using 3 × 25 mm plasterboard screws. There was no sealant used between the interface of the collar and the wall with the sealant attached to the plasterboard only or the pipes and the wall. The annular gap between the pipes and the collar was in-filled with FireMastic-HPE to the depth of collar and finished flush with the outer face of the collar.	-/60/60

Cables	Reference test	Maximum aperture (mm)	Sealant configuration	FRL
One sided penetration (unexposed side) Polyaire Paircoil 6.35 mm/9.52 mm insulated copper pipes with non-rated insulation lagging 1.5 mm ² 2C+E TPS power cable 16 mm ² PVC flexible outlet pipe.	FSP 1791 - Specimen 2	80 mm	The annular gap around the bunch of the paircoil, conduit and cable were sealed with FireMastic-HPE sealant to a nominal depth of 13 mm controlled by foam backing rod and finished flush with the surface of the wall.	-/60/60
One sided penetration (exposed side) Polyaire paircoil insulated copper pipe 1.5 mm ² 2C+E TPS Ø 16 mm Polyaire top condition outlet pipe	EWFA 2891600b.3 Specimen E	80 mm	The sealant was applied in the annular gap between pipe bundle and aperture on both sides of the separating element to a depth of 13 mm. The services were coming out of the cavity from the exposed side only.	-/60/60
<ul style="list-style-type: none"> LINK Fire Retardant Pair Coil with Ø9.5 mm and Ø15.8 mm copper pipe and lagging. Nexans Olex WK32 2015 V90 electric cables. Electra cables 2015 EAS7501P cable V-90 RoHS 	37995200.3	80 mm	A second layer of 16 mm fire rated plasterboard 150 mm × 150 mm placed over the penetration (on both sides) and secured to the wall. The edges of the plasterboard build up was coated with a 16 mm × 16 mm fillet of BOSS FireMastic-300 sealant. The resulting annular gap around the bunch sealed on both sides of the wall with FireMastic-HPE sealant to a nominal depth of 26 mm and finished with 10 mm × 10 mm fillet with the wall.	-/90/90

8.3.2 Discussion

Assessment of various HVAC service sizes

It is proposed to assess HVAC services with a smaller size than those tested. It is considered that reducing the service size will reduce the size or number of conductors and the number of combustible materials, such as cable sheathing. Hence, the amount of heat transferred to the unexposed side is expected to be lower when the service size is decreased. Therefore, it is expected that installing a smaller HVAC service will not detrimentally affect the system's performance, provided that the annular gap size and the sealant configuration are maintained as tested and the pipe insulation also remains as tested.

The tested services in the HVAC bundle represent the maximum number of services, and services are allowed to be removed from the bundle provided the annular gap and depth (and fillet, if applicable) are maintained.

8.3.3 Conclusion

The technical review found that the HVAC services protected by BOSS FireMastic-HPE sealant are expected to achieve the fire resistance levels (FRL) given in Table 52 – in accordance with AS 1530.4:2014 and assessed in accordance with AS 4072.1:2005.

Table 50 Assessment outcome of HVAC bundle with or without cables in a single layer flexible wall system

Services	Maximum aperture (mm)	Separating element thickness (mm)	Sealant configuration	FRL
Up to Paircoil 10 mm/15 mm insulated copper pipes with non-rated insulation lagging Up to 2.5-mm ² 2C+E TPS power cable, and a 1.5 mm ² 2-core data cable Up to 20 mm uPVC outlet pipe.	80 mm	90 mm	A second layer of 13 mm fire rated plasterboard 150 mm × 150 mm placed over the penetration (on both sides) and secured to the wall. The edges of the plasterboard build up coated with a 13 mm × 13 mm fillet of BOSS FireMastic-300 sealant. The resulting annular gap around the bunch sealed on both sides of the wall with FireMastic-HPE sealant to a nominal depth of 26 mm and finished flush with the wall.	-/60/60
Up to Paircoil 10 mm/15 mm insulated copper pipes with non-rated insulation lagging Up to 2.5-mm ² 2C+E TPS power cable, and a 1.5 mm ² 2-core data cable	80 mm	90 mm	On both sides of the wall BOSS MaxiCollar is surface mounted to the plasterboard using 3 × 25 mm plasterboard screws. No sealant to be used between the interface of the collar and the wall with the sealant attached to the plasterboard only or the pipes and the wall. The annular gap between the pipes and the collar in-filled with FireMastic-HPE to the depth of collar and finished flush with the outer face of the collar.	-/60/60

Services	Maximum aperture (mm)	Separating element thickness (mm)	Sealant configuration	FRL
<ul style="list-style-type: none"> LINK Fire Retardant Pair Coil with Ø9.5 mm and Ø15.8 mm copper pipe and lagging. Nexans Olex WK32 2015 V90 electric cables. Electra cables 2015 EAS7501P cable V-90 RoHS 	80 mm	124 mm	A second layer of 16 mm fire rated plasterboard 150 mm × 150 mm placed over the penetration (on both sides) and secured to the wall. The edges of the plasterboard build up was coated with a 16 mm × 16 mm fillet of BOSS FireMastic-300 sealant. The resulting annular gap around the bunch sealed on both sides of the wall with FireMastic-HPE sealant to a nominal depth of 26 mm and finished with 10 mm × 10 mm fillet with the wall.	-/90/90
<p>One sided penetration</p> <p>Paircoil up to 6.35 mm/9.52 mm insulated copper pipes with non-rated insulation lagging</p> <p>Up to 1.5 mm² 2C+E TPS power cable</p> <p>Up to 16 mm² PVC flexible outlet pipe.</p>	80 mm	90 mm	The annular gap around the bunch of the paircoil, conduit and cable sealed with FireMastic-HPE sealant to a nominal depth of 13 mm controlled by foam backing rod and finished flush with the surface of the wall.	-/60/60
<p>One sided penetration (exposed side)</p> <p>paircoil insulated copper pipe</p> <p>Up to 1.5 mm² 2C+E TPS</p> <p>Up to Ø 16 mm Polyaire top condition outlet pipe</p>	80 mm	90 mm	The sealant was applied in the annular gap between pipe bundle and aperture on both sides of the separating element to a depth of 13 mm	-/60/60

8.4 Assessment of various HVAC bundle with or without cables in minimum 116 mm flexible wall system protected by BOSS FireMastic-HPE sealant

8.4.1 Proposed construction

Table 51 lists the HVAC services tested in test reports FSP1734.

Table 51 Tested HVAC bundle with or without cables in flexible wall system

Service	Reference test	Maximum aperture (mm)	Sealant configuration	FRL
<ul style="list-style-type: none"> Paircoil (16 mm OD and 10 mm OD copper pipe) insulated with 13 mm thick rubber foam insulation. 20 mm OD PVC conduit 2.5 mm² 2-core plus earth TPS cable 1 mm² 2 core data cable 	FSP1734	125 mm	The bunch of paircoil, conduit and cables were sealed on both sides of the wall with FireMastic-HPE sealant to a nominal depth of 25 mm controlled by foam backing rod. Sealant finished with a nominal 25 mm fillet.	-/120/120
<ul style="list-style-type: none"> Paircoil (16 mm OD and 10 mm OD copper pipe) insulated with 13 mm thick rubber foam insulation. 1.5 mm² 6 core electric cable 		100 mm	The bunch of paircoil, and cables were sealed on both sides of the wall with FireMastic-HPE sealant to a nominal depth of 25 mm controlled by foam backing rod. Sealant finished with a nominal 25 mm fillet.	-/120/120

8.4.2 Discussion

Assessment of various HVAC service sizes

It is proposed to assess HVAC services with a smaller size than those tested. It is considered that reducing the service size will reduce the size or number of conductors and the number of combustible materials, such as cable sheathing. Hence, the amount of heat transferred to the unexposed side is expected to be lower when the service size is decreased. Therefore, it is expected that installing a smaller HVAC service will not detrimentally affect the system's performance, provided that the annular gap size and the sealant configuration are maintained as tested and the pipe insulation also remains as tested.

The tested services in the HVAC bundle represent the maximum number of services, and services are allowed to be removed from the bundle provided the annular gap and depth (and fillet, if applicable) are maintained.

8.4.3 Conclusion

The technical review found that the HVAC services protected by BOSS FireMastic-HPE sealant are expected to achieve the fire resistance levels (FRL) given in Table 52 – in accordance with AS 1530.4:2014 and assessed in accordance with AS 4072.1:2005.

Table 52 Assessment outcome of HVAC bundle with or without cables in 116 mm flexible wall system

services	Maximum aperture (mm)	Sealant configuration	FRL
paircoil insulated copper pipe Up to 1.5 mm 2C+E TPS Up to 16 mm diameter Polyaire top condition outlet pipe	80 mm	13 mm deep both sides finished flush	-/60/60
Paircoil 10 mm/15 mm insulated copper pipes with non-rated insulation lagging Up to 2.5-mm ² 2C+E TPS power cable, and a up to 1.5 mm ² 2-core data cable Up to 20 mm uPVC outlet pipe.	80 mm	The resulting annular gap around the bunch sealed on both sides of the wall with FireMastic-HPE sealant to a nominal depth of 26 mm and finished flush with the wall.	-/60/60

services	Maximum aperture (mm)	Sealant configuration	FRL
Paircoil 10 mm/15 mm insulated copper pipes with non-rated insulation lagging Up to 2.5-mm ² 2C+E TPS power cable, Up to 1.5 mm ² 2-core data cable	80 mm	On both sides of the wall BOSS MaxiCollar is surface mounted to the plasterboard using 3 × 25 mm plasterboard screws. No sealant to be used between the interface of the collar and the wall with the sealant attached to the plasterboard only or the pipes and the wall. The annular gap between the pipes and the collar in-filled with FireMastic-HPE to the depth of collar and finished flush with the outer face of the collar.	-/60/60
<ul style="list-style-type: none"> Paircoil (16 mm OD and 10 mm OD copper pipe) insulated with 13 mm thick rubber foam insulation. Up to 20 mm OD PVC conduit Up to 2.5 mm² 2-core plus earth TPS cable Up to 1 mm² 2 core data cable 	125 mm	The bunch of paircoil, conduit and cables were sealed on both sides of the wall with FireMastic-HPE sealant to a nominal depth of 25 mm controlled by foam backing rod. Sealant finished with a nominal 25 mm fillet.	-/120/120
<ul style="list-style-type: none"> Paircoil (16 mm OD and 10 mm OD copper pipe) insulated with 13 mm thick rubber foam insulation. Up to 1.5 mm² 6 core electric cable 	100 mm	The bunch of paircoil, and cables were sealed on both sides of the wall with FireMastic-HPE sealant to a nominal depth of 25 mm controlled by foam backing rod. Sealant finished with a nominal 25 mm fillet.	-/120/120
Up to TBS cable and data cable + up to 20 mm OD PVC conduit + three copper pipes (up to 20 mm) insulated with 13 mm Armaflex foamed nitrile rubber wrap	Up to 125 mm diameter	Annular gap sealed with Boss FireMastic-HPE sealant to a nominal depth of 25 mm controlled by foam backing rod. Sealant finished with a nominal 25 mm fillet on both sides of the wall.	-/120/120

8.5 Assessment of various HVAC bundle with or without cables in minimum 75 mm AAC wall system protected by BOSS FireMastic-HPE sealant

8.5.1 Proposed construction

Table 53 lists the HVAC services tested in FRT210322.1 and FRT220141 in accordance with AS 1530.4:2014.

In test FRT210322.1, the tested system included 75 mm thick AAC wall system penetrated with 18 services. The HVAC services protected with BOSS FireMastic-HPE sealant are discussed in this section.

In test FRT220141 R1.1, the tested system included 75 mm thick AAC wall system penetrated with 9 services. The HVAC services protected with BOSS FireMastic-HPE sealant are discussed in this section.

Table 53 Tested HVAC bundle with or without cables fitted in AAC wall system

Service	Reference test	Maximum aperture (mm)	Sealant configuration	FRL
1 × 3/8 + 3/4 FR paircoil with 19 mm thick insulation - 0.8 mm / 1.1 mm thick	FRT210322.1	127 mm	20 mm deep finished with 25 mm × 25 mm fillet on both sides as shown in Figure 6	-120/90
1 × Ø20 mm UPVC pipe - 1.4 mm thick				
1 × 2.5 mm ² 3C+E TPS cable				
1 × CAT6 cable				
1 × 3/8 + 5/8 FR paircoil w/ 19 mm thick insulation - 0.8 mm / 1.0 mm thick	FRT210322.1	127 mm	20 mm deep finished with 25 mm × 25 mm fillet on both sides as shown in Figure 6	-120/120
1 × Ø20 mm UPVC pipe - 1.4 mm thick				
1 × 2.5 mm ² 3C+E TPS cable				
1 × CAT6 cable				
1 × 3/8 + 5/8 FR paircoil with 13 mm thick insulation - 0.8mm / 1.0 mm thick	FRT210322.1	100 mm	20 mm deep finished with 25 mm × 25 mm fillet on both sides as shown in Figure 6	-120/90
1 × Ø20 mm UPVC pipe - 1.4 mm thick				
1 × 2.5 mm ² 3C+E TPS cable				
1 × CAT6 cable				
1 × 3/8 + 3/4 FR paircoil w/ 19 mm thick insulation - 0.8 mm / 1.1 mm thick	FRT210322.1	152 mm	20 mm deep finished with 25 mm × 25 mm fillet on both sides as shown in Figure 6	-120/120
1 × DN32 type B copper pipe (1.2 mm thick) with Ø32 mm SUpaCell pipe lagging – 25 mm thick				
1 × 3/8 + 5/8 FR paircoil w/ 13 mm thick insulation - 0.8 mm / 1.0 mm thick				
3/8 + 5/8 FR paircoil with 9 mm non fire rated lagging- 0.8 mm / 1.0 mm thick 20 mm condensation pipe - 1.5 mm wall thickness 2×2.5 mm ² 2C+E TPS cable 2 × CAT 6 cable	FRT220141	80 mm	25 mm deep both sides finished with 20 mm × 20 mm fillet as shown in Figure 6	-120/120

8.5.2 Discussion

Improvements to insulation performance

In the reference test FRT210322.1, combination A, consists of 1 × 3/8 + 3/4 FR paircoil with 19 mm thick insulation - 0.8 mm / 1.1 mm thick, 1 × Ø20 mm UPVC pipe - 1.4 mm thick, 1 × 2.5 mm² 3C+E TPS cable and 1 × CAT5e cable. The services were protected with BOSS FireMastic-HPE sealant applied in the annular gap between the services and the separating element to a depth of 20 mm with PE backing rod support and finished with a 25 mm × 25 mm fillet on both the exposed and unexposed sides of the separating element. The services performed 120 minutes integrity and 90 minutes insulation. The insulation failure occurred at 107 minutes. The test was conducted on a single mesh Hebel wall which has an established FRL of -/90/90. The failure on the Hebel face can be attributed to the capacity of the wall. Installation in a double mesh is expected to achieve -/120/120.

In the reference test FRT210322.1, combination K, consists of 1 × 3/8 + 5/8 FR paircoil with 13 mm thick insulation - 0.8mm / 1.0 mm thick, 1 × Ø20 mm UPVC pipe - 1.4 mm thick, 1 × 2.5 mm² 3C+E TPS cable and 1 × CAT5e cable. The services were protected with BOSS FireMastic-HPE sealant applied in the annular gap between the services and the separating element to a depth of 20 mm with PE backing rod support and finished with a 25 mm × 25 mm fillet on both the exposed and unexposed sides of the separating element. The services performed 120 minutes integrity and 90 minutes insulation. The insulation failure occurred at 110 minutes. A thermocouple that was placed on the Hebel (25 mm away from the surface) recorded a temperature higher than 180C° above the ambient temperature. The test was conducted on a single mesh Hebel wall which has an established FRL of -/90/90. The failure on the Hebel face can be attributed to the capacity of the wall. Installation in a double mesh is expected to achieve -/120/120.

Assessment of various HVAC service sizes

It is proposed to assess HVAC services with a smaller size than those tested. Reducing the service size will reduce the size or the number of conductors and number of combustible materials, such as cable sheathing. Hence, the amount of heat transferred to the unexposed side is expected to be lower when the service size is decreased. Therefore, it is expected that installing a smaller HVAC service will not detrimentally affect the system performance, provided that the annular gap size and the sealant configuration are maintained as tested.

The tested services in the HVAC bundle represent the maximum number of services, and services are allowed to be removed from the bundle provided the annular gap and depth (and fillet, if applicable) are maintained.

8.5.3 Conclusion

The technical review found that the HVAC services protected by BOSS FireMastic-HPE sealant are expected to achieve the fire resistance levels (FRL) given in Table 54 – in accordance with AS 1530.4:2014 and assessed in accordance with AS 4072.1:2005. The service sizes listed below is the maximum, smaller sizes and diameters are also included.

Table 54 Assessment outcome of HVAC bundle with or without cables in min 75 mm thick AAC/ Rigid wall systems

Service	Maximum aperture (mm)	Sealant configuration	FRL
Up to 3/8 + 3/4 FR paircoil with 19 mm thick insulation - 0.8 mm / 1.1 mm thick	127	20 mm deep finished with 25 mm × 25 mm fillet on both sides as shown in Figure 6	-/120/120
Up to Ø20 mm UPVC pipe - 1.4 mm thick			
Up to 2.5 mm ² 3C+E TPS cable			
Up to CAT6 cable			
Up to 3/8 + 5/8 FR paircoil w/ 19 mm thick insulation - 0.8 mm / 1.0 mm thick	127	20 mm deep finished with 25 mm × 25 mm fillet on both sides as shown in Figure 6	-/120/120
Up to Ø20 mm UPVC pipe - 1.4 mm thick			

Service	Maximum aperture (mm)	Sealant configuration	FRL
Up to 2.5 mm ² 3C+E TPS cable			
Up to CAT6 cable			
Up to 3/8 + 5/8 FR paircoil with 13 mm thick insulation - 0.8mm / 1.0 mm thick	100	20 mm deep finished with 25 mm × 25 mm fillet on both sides as shown in Figure 6	-/120/120
Up to Ø20 mm UPVC pipe - 1.4 mm thick			
Up to 2.5 mm ² 3C+E TPS cable			
Up to CAT6 cable			
Up to 3/8 + 3/4 FR paircoil w/ 19 mm thick insulation - 0.8 mm / 1.1 mm thick	152	20 mm deep finished with 25 mm × 25 mm fillet on both sides as shown in Figure 6	-/120/120
Up to DN32 type B copper pipe (1.2 mm thick) with Ø32 mm SUpaCell pipe lagging – 25 mm thick			
Up to 3/8 + 5/8 FR paircoil w/ 13 mm thick insulation - 0.8 mm / 1.0 mm thick			
<ul style="list-style-type: none"> Up to 3/8 + 5/8 FR paircoil with 9 mm non fire rated lagging- 0.8 mm / 1.0 mm thick Up to 20 mm condensation pipe - 1.5 mm wall thickness Up to 2×2.5 mm² 2C+E TPS cable Up to 2 × CAT 6 cable 	80	25 mm deep both sides with 20 mm × 20 mm fillet as shown in Figure 6	-/120/120
TBS cable and data cable + up to 20 mm OD PVC conduit + three copper pipes (up to 20 mm) insulated with 13 mm Armaflex foamed nitrile rubber wrap.	Up to 125 mm in diameter	Annular gap sealed with Boss FireMastic-HPE sealant to a nominal depth of 25 mm controlled by foam backing rod. Sealant finished with a nominal 25 mm fillet on both sides of the wall.	-/120/120

8.6 Assessment of various HVAC bundle with or without cables in minimum 130 mm thick CLT timber wall protected by BOSS FireMastic-HPE sealant

8.6.1 Proposed construction

Table 55 lists HVAC services tested in FRT210330 in accordance with AS 1530.4:2014.

In the reference test FRT210330, the tested system included a 130 mm thick CLT wall system penetrated with 9 services. The HVAC services protected with BOSS FireMastic-HPE sealant are considered in this section.

Table 55 Tested HVAC bundle with or without cables in CLT timber wall

Services	Reference test	Maximum aperture (mm)	Sealant configuration	FRL
<ul style="list-style-type: none"> 3/8' + 3/4' FR paircoil w/ 19 mm thick insulation - 1.4 mm / 2.8 mm thick 20 mm condensation drain pipe - 1.8 mm thick 2.5 mm² 3C+E TPS cable 2.5 mm² 2C+E TPS cable 	FRT210330	121 mm	20 mm deep both finished flush as shown in Figure 7	-/90/90

Services	Reference test	Maximum aperture (mm)	Sealant configuration	FRL
• Instrolex control cable				

8.6.2 Discussion

Assessment of various HVAC service sizes

In the reference test FRT210330, specimen H, a 121 mm aperture was made in a 130 mm thick CLT timber wall system. HVAC services were placed in the aperture, and the annular gap was sealed with BOSS FireMastic-HPE sealant to a depth of 20 mm in both exposed and unexposed sides and finished flush with the wall. The tested services were 3/8 + 3/4 FR paircoil, 20 mm condensation drainpipe, 2.5 mm² 3C+E TPS cable and Instrolex control cable. The system was tested for 100 minutes. During the test, the thermocouple placed on the service and the wall at 25 mm away from the aperture recorded a lower temperature than 180 C°. The HVAC service-maintained integrity and insulation for 90 minutes.

It is proposed to assess HVAC services with a smaller size than those tested. Reducing the service size will reduce the size or number of conductors and the amount of combustible materials, such as cable sheathing. Hence, the amount of heat transferred to the unexposed side is expected to be lower when the service size is decreased. Therefore, it is expected that installing a smaller HVAC service will not detrimentally affect the system's performance, provided that the annular gap size and the sealant configuration are maintained as tested.

The tested services in the HVAC bundle represent, the maximum number of services, and services are allowed to be removed from the bundle provided the annular gap and depth (and fillet, if applicable) are maintained.

8.6.3 Conclusion

The technical review found that the HVAC services protected by BOSS FireMastic-HPE sealant are expected to achieve the fire resistance levels (FRL) given in Table 56 – in accordance with AS 1530.4:2014 and assessed in accordance with AS 4072.1:2005.

Table 56 Assessment of HVAC bundle with or without cables in CLT wall

Services	Maximum aperture (mm)	Sealant configuration	FRL
Up to 3/8 + 3/4 FR paircoil w/ 19 mm thick insulation - 1.4 mm / 2.8 mm thick Up to 20 mm condensation drain pipe - 1.8 mm thick Up to 2.5 mm ² 3C+E TPS cable 2.5 mm ² 2C+E TPS cable Up to Instrolex control cable	121 mm	20 mm deep both finished flushes as shown in Figure 7	-/90/90

8.7 Assessment of various HVAC services in minimum 235 mm thick ceiling protected by BOSS FireMastic-HPE sealant

8.7.1 Proposed construction

Table 57 lists the HVAC services tested in FRT180474.3 in accordance with AS 1530.4:2014.

In the reference test FRT180474.3, a 235 mm thick ceiling system was penetrated with 10 services and protected with various local fire stopping protections. The ceiling consists of 2 layers of 13 mm fire-rated plasterboard fixed directly onto the timber framing on the exposed side using plasterboard screws at nominal 150 mm centres on the joist and 100 mm centres on the perimeter framing. On the unexposed side, particleboard flooring was fixed directly onto the timber framing. The sealant used in the ceiling system was BOSS FireMastic-HPE sealant, and the sealant used in the timber flooring system was BOSS FireMastic-300. This section will discuss the HVAC services protected with BOSS FireMastic-HPE sealant.

Table 57 Tested HVAC bundle with or without cables in ceiling system

Services	Reference test	Maximum aperture (mm)	Sealant configuration	FRL	RISF
<ul style="list-style-type: none"> • 1 × TPS - 2.5 mm²2C+E cable • 1 × Cat 6 cable • 1 × 3/8 & 5/8 Paircoil FR • Up to 25 mm UPVC conduit – 2 mm wall thickness" 	FRT180474.3	72 mm	<p>FireMastic - HPE – On the interface between the fire collar and the service to the depth of the fire collar and finished flush with the fire collar.</p> <p>FireMastic 300 – on the interface between the service and particleboard flooring to the depth of particleboard flooring on the unexposed side and finished flush with the surface</p>	-/90/90	Failure at 53 minutes

8.7.2 Discussion

Assessment of various HVAC service sizes

In the reference test FRT180474.3, specimen I, a 72 mm diameter aperture was made in a 235 mm thick ceiling system. The aperture was penetrated with 1 × TPS - 2.5 mm²2C+E cable, 1 × Cat 6 cable, 1 × Paircoil FR - Ø16 mm and 1 × 25 mm UPVC conduit. The services were protected with BOSS FireMastic-HPE sealant applied on the interface between the fire collar and the service to the depth of the fire collar, and finished flush with the fire collar and BOSS FireMastic 300 applied on the interface between the service and particleboard flooring to the depth of particleboard flooring on the unexposed side and finished flush with the surface. The HVAC service failed RISF at 53 minutes. However, it maintained integrity and insulation performance for up to 90 minutes.

In test FRT180474.3, specimen J, a 51 mm diameter aperture was made in a 235 mm thick ceiling system. The aperture was penetrated with 2 × 25 mm UPVC conduit and 2 × TPS - 2.5 mm² 2C+E cables. The HVAC services were protected with BOSS FireMastic-HPE sealant applied on the interface between the fire collar and the service to the depth of the fire collar, and finished flush with the fire collar and BOSS FireMastic 300 applied on the interface between the service and particleboard flooring to the depth of the particleboard flooring on the unexposed side and finished flush with the surface. The system failed RISF after 24 minutes. However, it maintained integrity and insulation for up to 90 minutes.

It is proposed to assess HVAC services with a smaller size than those tested. Reducing the service size will reduce the size and the number of conductors and number of combustible materials, such as cable sheathing. Hence, the amount of heat transferred to the unexposed side is expected to be lower when the service size is decreased. Therefore, it is expected that, installing a smaller HVAC service will not detrimentally affect the system's performance, provided that the annular gap size and the sealant configuration is maintained as tested.

The tested services in the HVAC bundle represents the maximum number of services and services are allowed to be removed from the bundle provided the annular gap and depth (and fillet if applicable) are maintained.

8.7.3 Conclusion

The technical review found that the HVAC services protected by BOSS FireMastic-HPE sealant are expected to achieve the fire resistance levels (FRL) given in Table 58– in accordance with AS 1530.4:2014 and assessed in accordance with AS 4072.1:2005.

Table 58 Assessment of HVAC bundle with or without cables in ceiling system

Services	Maximum aperture (mm)	Sealant configuration	FRL	RISF
Up to TPS - 2.5 mm ² 2C+E cable Up to 1 × Cat 6 cable Up to 1 × 3/8 & 5/8 Paircoil FR Up to 25 mm uPVC conduit – 2 mm wall thickness	72 mm	BOSS FireMastic HPE – On the interface between the fire collar and the service to the depth of the fire collar and finished flush with the fire collar FireMastic 300 – on the interface between the service and particleboard flooring to the depth of particleboard flooring on the unexposed side and finished flush with the surface	-/90/90	Failure at 53 minutes

8.8 Assessment of various HVAC services in minimum 150 mm thick concrete slab protected by BOSS FireMastic-HPE sealant

8.8.1 Proposed construction

Table 59 lists the HVAC services tested in FRT220049 in accordance with AS 1530.4:2014.

In the reference test FRT220049, a 150 mm concrete floor system was tested. The slab was penetrated by 10 various services. The services were protected with different fire stopping protections. This section discusses the HVAC service penetration protected with BOSS FireMastic-HPE sealant.

Table 59 Tested HVAC bundle with or without cables in concrete slab

Services	Reference test	Maximum aperture (mm)	Sealant configuration	FRL
<ul style="list-style-type: none"> 1 1/8 (28.6 mm) copper pipe with 25 mm thick E-Flex ST lagging - 1.2 mm wall thickness 7/8" (22 mm) copper pipe with 25 mm thick E-Flex ST lagging - 1.6 mm wall thickness DN 18 copper pipe with 19 mm lagging - 1.3 mm wall thickness 20 mm condensation drainpipe - 1.5 mm wall thickness 2.5 mm² 3C+E TPS cable 2.5 mm² 2C+E TPS cable Instrolex control cable 	FRT220049	150 mm	25 mm - Both sides Finished flush	- /240/120
<ul style="list-style-type: none"> 3/8 + 3/4 FR paircoil w/ 19 mm thick insulation - 1.4mm / 2.8mm thick 2.5mm² 3C+E TPS cable CAT 6 cable Instrolex control cable 2.5mm² 2C+E TPS cable 20 mm condensation drainpipe - 1.5 mm wall thickness 	FRT220049	100 mm	25 mm - Both sides with backing rod Finished flush	- /240/240

8.8.2 Discussion

Assessment of various HVAC service sizes

In the reference test FRT220049, Specimen A, a 150 mm aperture was made in a 150 mm thick concrete slab. The aperture was penetrated with the following HVAC services 1 1/8" (28.6 mm) copper pipe with 25 mm thick E-Flex ST lagging, 7/8" (22 mm) copper pipe with 25 mm thick E-Flex ST lagging, DN 18 copper pipe with 19 mm lagging, 20 mm condensation drainpipe, 2.5 mm² 3C+E TPS cable, Fire alarm cable and Instrolex control cable. The services were protected with BOSS FireMastic-HPE sealant applied to a depth of 25 mm in both exposed and unexposed sides and finished flush with the floor. The service failed insulation at 124 minutes as the thermocouple positioned on the TPS cable recorded a high temperature. However, it continued to maintain integrity performance for 240 minutes.

In test FRT220049, specimen I, a 100 mm diameter aperture was penetrated with the following HVAC services, 3/8 + 3/4 FR paircoil, 2.5 mm² 3C+E TPS cable, CAT 6 cable, Instrolex control cable, 2.5 mm² 2C+E TPS cable and 20 mm condensation drainpipe. The services were protected with BOSS FireMastic-HPE sealant, applied to a depth of 25 mm on both exposed and unexposed sides with backing rod and finished flush with the floor. The service maintained integrity and insulation performance for 240 minutes.

It is proposed to assess HVAC services with a smaller size than those tested. Reducing the service size will reduce the size and the number of conductors and number of combustible materials, such as cable sheathing. Hence, the amount of heat transferred to the unexposed side is expected to be lower when the service size is decreased. Therefore, it is expected that, installing a smaller HVAC service will not detrimentally affect the system's performance, provided that the annular gap size and the sealant configuration is maintained as tested.

The tested services in the HVAC bundle represents the maximum number of services and services are allowed to be removed from the bundle provided the annular gap and depth (and fillet if applicable) are maintained.

8.8.3 Conclusion

The technical review found that the HVAC services protected by BOSS FireMastic-HPE sealant are expected to achieve the fire resistance levels (FRL) given in Table 60 – in accordance with AS 1530.4:2014 and assessed in accordance with AS 4072.1:2005.

Table 60 Assessment outcome of HVAC bundle with or without cables in concrete slab

Services	Maximum aperture (mm)	Sealant configuration	FRL
<ul style="list-style-type: none"> Up to 1 1/8" (28.6 mm) copper pipe with 25 mm thick E-Flex ST lagging - 1.2 mm wall thickness Up to 7/8" (22 mm) copper pipe with 25 mm thick E-Flex ST lagging - 1.6 mm wall thickness Up to DN 18 copper pipe with 19 mm lagging - 1.3 mm wall thickness Up to 20 mm condensation drain pipe - 1.5 mm wall thickness Up to 2.5 mm² 3C+E TPS cable Up to 2.5 mm² 2C+E TPS cable Instrolex control cable 	150	25 mm - Both sides Finished flush.	- /240/120

Services	Maximum aperture (mm)	Sealant configuration	FRL
<ul style="list-style-type: none"> Up to 3/8 + 3/4 FR paircoil w/ 19 mm thick insulation - 1.4mm / 2.8mm thick Up to 2.5mm² 3C+E TPS cable Up to CAT 6 cable Instrolex control cable Up to 2.5mm² 2C+E TPS cable Up to 20 mm condensation drain pipe - 1.5 mm wall thickness 	100	25 mm - Both sides with backing rod Finished flush	- /240/240

8.9 Assessment of HVAC bundle with or without cables in ComFlor60 (Max 130 mm thick / min 70 mm thick)

8.9.1 Proposed construction

Table 61 lists the services tested in FRT180137 in accordance with AS 1530.4:2014.

In the reference test FRT180137, a composite floor system with a maximum thickness of 130 mm and a minimum thickness of 70 mm was penetrated with 9 various services. The pipe services protected by BOSS FireMastic-HPE sealant are considered in this section.

Table 61 Tested HVAC bundle with or without cables in ComFlor60

Pipe	Reference test	Nominal pipe diameter (mm)	Maximum aperture (mm)	Sealant configuration	FRL
Pair coil copper pipe with lagging	FRT180137	16 and 6	100 mm	25 mm deep and finished flush on the unexposed side.	-/120/120
uPVC	FRT180137	25		25 mm in the recess between the batt and the service from the exposed side	

8.9.2 Discussion

Assessment of various pipe sizes

In FRT 180137 R2.0, a ComFlor®60 composite floor system with a maximum thickness of 130 mm and a minimum thickness of 70 mm was tested. Specimen C was a paircoil pipe and 25 mm UPVC drain pipe in 100 mm diameter aperture. It was protected by BOSS FireMastic-HPE sealant. The sealant was applied 25 mm deep and finished flush on the unexposed side and 25 mm in the recess between the Batt and the service from the exposed side.

Specimen C achieved an integrity and insulation performance of 121 minutes with no failure for the test duration. Test photographs show that the service was installed in the top rib of the Comflor60. Therefore, it is expected that combustible and insulated metal pipes of a diameter equal to or smaller than the tested service size will achieve at least similar integrity and insulation performance as the tested size.

It is proposed to assess HVAC services with a smaller size than those tested. Reducing the service size will reduce the size and the number of conductors and number of combustible materials, such as cable sheathing. Hence, the amount of heat transferred to the unexposed side is expected to be lower when the service size is decreased. Therefore, it is expected that, installing a smaller HVAC service will not detrimentally affect the system's performance, provided that the annular gap size and the sealant configuration is maintained as tested.

The tested services in the HVAC bundle represents the maximum number of services and services are allowed to be removed from the bundle provided the annular gap and depth (and fillet if applicable) are maintained.

8.9.3 Conclusion

The technical review found that the pipes protected by BOSS FireMastic-HPE sealant are expected to achieve the fire resistance levels (FRL) given in Table 62 – in accordance with AS 1530.4:2014 and assessed in accordance with AS 4072.1:2005.

Table 62 Assessment outcome of HVAC bundle with or without cables penetration in ComFlor60

Pipe	Nominal pipe diameter (mm)	Maximum aperture (mm)	Sealant configuration	FRL
Pair coil copper pipe with lagging	Up to 16 and 6	100 mm	25 mm deep and finished flush on the unexposed side. 25 mm in the recess between the Batt and the service from the exposed side	-/120/120
uPVC	Up to 25			

9. Validity

Warringtonfire Australia does not endorse the tested or assessed products and systems in any way. The conclusions of this assessment may be used to directly assess fire resistance, but it should be recognised that a single test method will not provide a full assessment of fire resistance under all conditions.

Due to the nature of fire testing and the consequent difficulty in quantifying the uncertainty of measurement, it is not possible to provide a stated degree of accuracy. The inherent variability in test procedures, materials and methods of construction, and installation may lead to variations in performance between elements of similar construction.

This assessment is based on test data, information and experience available at the time of preparation. If contradictory evidence becomes available to the assessing authority, the assessment will be unconditionally withdrawn and the report sponsor will be notified in writing. Similarly, the assessment should be re-evaluated, if the assessed construction is subsequently tested since actual test data is deemed to take precedence.

The procedures for the conduct of tests and the assessment of test results are subject to constant review and improvement. The sponsor is therefore recommended that this report be reviewed on, or before, the stated expiry date.

This assessment represents our opinion about the performance of the proposed systems that is expected to be demonstrated when subjected to test conditions in accordance with AS 1530.4:2014, based on the evidence referred to in this report.

This assessment is provided to Boss Products Australia Pty Ltd for their own specific purposes. This report may be used as evidence of suitability in accordance with the requirements of the relevant National Construction Code. Building certifiers and other third parties must determine the suitability of the systems described in this report for a specific installation.

Appendix A Summary of supporting test data

A.1 Test report – FSP 1734

Table 63 Information about test report

Item	Information about test report
Report sponsor	Boss Products (Australia) Pty Ltd
Test laboratory	Infrastructure Technologies, 14 Julius Avenue, North Ryde, NSW 2113.
Test date	The fire resistance test was done on 9 December 2015.
Test standards	The test was done in accordance with AS 1530.4:2014
Variation to test standards	None
General description of tested specimen	A specimen consists of seven services penetrating a plasterboard wall and protected by sealants. The plasterboard wall system consists of double layer of 13 mm plasterboard wall with an established FRL of - /120/120
Instrumentation	The test report states that the instrumentation was in accordance with AS 1530.4:2014

The test specimen achieved the following results – see Table 64.

Table 64 Results summary for this test report

Penetration system/ linear joint seal	Criteria	Results
Specimen 1	Structural adequacy	-
	Integrity	121
	Insulation	121
Specimen 2	Structural adequacy	-
	Integrity	121
	Insulation	121
Specimen 3	Structural adequacy	-
	Integrity	121
	Insulation	121
Specimen 4	Structural adequacy	-
	Integrity	121
	Insulation	121
Specimen 5	Structural adequacy	-
	Integrity	121
	Insulation	121
Specimen 6	Structural adequacy	-
	Integrity	121
	Insulation	121
Specimen 67	Structural adequacy	-
	Integrity	121
	Insulation	121

A.2 Test report – Chilt/RF12089A AR5

Table 65 Information about test report

Item	Information about test report
Report sponsor	Boss Fire and Safety
Test laboratory	Exova Warringtonfire, Chiltern House, Stocking Lane, Hughenden Valley, High Wycombe Buckinghamshire, HP14 4ND
Test date	The fire resistance test was done on 15 August 2012.
Test standards	The test was done in accordance with BSEN 1366-3:2009 and BSEN 1366-4: 2009.
Variation to test standards	None
General description of tested specimen	<p>Nine service penetration sealing systems were installed into two flexible supporting constructions and a vertical linear joint sealing system was installed between the left flexible supporting construction and a blockwork wall.</p> <p>Two horizontal linear joint seals, a vertical linear joint seal, and nine service penetrations were also tested, but are not subject to this report.</p>
Instrumentation	The test report states that the instrumentation was in accordance with BSEN 1366-3:2009 and BSEN 1366-4: 2009.

The test specimen achieved the following results – see Table 66.

Table 66 Results summary for this test report

Penetration system/ linear joint seal	Criteria	Results
Pipe 1	Structural adequacy	-
	Integrity	132
	Insulation	132
Pipe 2	Structural adequacy	-
	Integrity	132
	Insulation	132
Pipe 3	Structural adequacy	-
	Integrity	132
	Insulation	132
Pipe 4	Structural adequacy	-
	Integrity	132
	Insulation	132
Pipe/cables 6	Structural adequacy	-
	Integrity	132
	Insulation	129
Linear joint seal 9	Structural adequacy	-
	Integrity	132
	Insulation	132

Penetration system/ linear joint seal	Criteria	Results
Pipe 14	Structural adequacy	-
	Integrity	132
	Insulation	132
Pipe 17	Structural adequacy	-
	Integrity	132
	Insulation	132
Pipe 21	Structural adequacy	-
	Integrity	132
	Insulation	106
Pipe 22	Structural adequacy	-
	Integrity	132
	Insulation	132

A.3 Test report – FSP 2073

Table 67 Information about test report

Item	Information about test report
Report sponsor	Knauf Plasterboard Pty Limited
Test laboratory	Infrastructure Technologies, 14 Julius Avenue, North Ryde, NSW 2113.
Test date	The fire resistance test was done on 13 January 2020.
Test standards	The test was done in accordance with AS 1530.4:2014.
Variation to test standards	None
General description of tested specimen	The specimens consisted a PE-Xa Rehau Rautitan pipe, a PVC pipe, and a bath breaching piece with two tap handles and a tap penetrating the exposed face of the Knauf shaftliner wall system. The penetrated wall consisted of 1 128 mm thick plasterboard lined framed wall system comprising a 25 mm thick Knauf shaftliner board on the exposed side and two layers of 13 mm thick Knauf Fireshield plasterboard on the unexposed side of the 102 mm 0.55 BMT CH-stud wall framing with 102 mm 0.55 BMT CH-studs. The wall cavity was filled with 75 mm thick Knauf Earthwool (density of 11 kg/m ³).
Instrumentation	The test report states that the instrumentation was in accordance with AS 1530.4:2014.

The test specimen achieved the following results – see Table 68.

Table 68 Results summary for this test report

Penetration system/ linear joint seal	Criteria	Results
Specimen 1	Structural adequacy	-
	Integrity	121
	Insulation	121
Specimen 2	Structural adequacy	-
	Integrity	121
	Insulation	121
Specimen 3	Structural adequacy	-
	Integrity	121
	Insulation	121

A.4 Test report – FSP 2191

Table 69 Information about test report

Item	Information about test report
Report sponsor	Boss Products (Australia) Pty Ltd
Test laboratory	Infrastructure Technologies, 14 Julius Avenue, North Ryde, NSW 2113.
Test date	The fire resistance test was done on 21 January 2021.
Test standards	The test was done in accordance with AS 1530.4:2014
Variation to test standards	None

Item	Information about test report
General description of tested specimen	Two plastic pipe penetrations and two Boss Fire transit boxes (with and without services) were installed in a framed plasterboard wall system.
Instrumentation	The test report states that the instrumentation was in accordance with AS 1530.4:2014.

The test specimen achieved the following results – see Table 70.

Table 70 Results summary for this test report

Penetration system/ linear joint seal	Criteria	Results
Specimen 1	Structural adequacy	-
	Integrity	121
	Insulation	121
Specimen 3	Structural adequacy	-
	Integrity	121
	Insulation	79
Specimen 4	Structural adequacy	-
	Integrity	121
	Insulation	121
Specimen 5	Structural adequacy	-
	Integrity	121
	Insulation	121

A.5 Test report – FRT210322

Table 71 Information about test report

Item	Information about test report
Report sponsor	Boss Products (Australia) Pty Ltd
Test laboratory	Warringtonfire, 409-411 Hammond Road, Dandenong South VIC 3175 Australia
Test date	The fire resistance test was done on 18 January 2022.
Test standards	The test was done in accordance with AS 1530.4:2014.
Variation to test standards	None

General description of tested specimen	The specimen comprised of 1600 mm wide by 1600 mm high by 75 mm thick penetrated by 18 services as listed below. The tested system was restrained on all edges.				
	Penetration system	Service	Local fire-stopping protection	Main fire-stopping protection	Aperture size (mm)
	A	1 × 3/8 + 3/4 FR paircoil with 19 mm insulation 1 × Ø20 mm UPVC pipe 1 × 2.5 mm ² 3C+E TPS cable 1 × CAT6 cable	BOSS FireMastic-HPE™	-	Ø127 mm
	B	1 × 3/8 + 5/8 FR paircoil w/ 19 mm insulation 1 × Ø20 mm UPVC pipe 1 × 2.5 mm ² 3C+E TPS cable 1 × CAT6 cable	BOSS FireMastic-HPE™	-	Ø127 mm
	C	2 × RG6 Coax cables 2 × CAT6 cables 2 × 4 Core security cables (7/0.20 mm)	BOSS FireMastic-HPE™	-	Ø40 mm
	D	Ø20 mm PEXa pipe	BOSS FireMastic-HPE™	-	Ø60 mm
	E	Ø20 mm PE-X/AL/PE-X pipe	BOSS FireMastic-HPE™	-	Ø60 mm
	F	1 × 16 mm ² 2C+E cable 4 × 2.5 mm ² 2C+E TPS cable 6 × RG6 Coax cables 10 × CAT6 cables 4 × 2.5 mm ² 3C+E cables 6 × 4 Core security cables (7/0.20 mm) 1 × Ø20 mm UPVC pipe 2 × 10 mm ² 2C+E power cables	BOSS FireMastic-300™ and BOSS P40-MAK wrap	BOSS Fire Cable Transit CT120-100R	Ø105 mm
	G	Ø20 mm HFT LSF0H conduit	BOSS FireMastic-HPE™	-	Ø60 mm
	H	Ø32 mm PVC conduit	BOSS FireMastic-HPE™	-	36 mm
I	Ø20 mm UPVC conduit	BOSS FireMastic-HPE™	-	24 mm	

Item	Information about test report				
	J	Ø32 mm UPVC conduit	BOSS FireMastic-HPE™	-	Ø73 mm
	K	1 × 3/8 + 5/8 FR paircoil with 13 mm insulation 1 × Ø20 mm UPVC pipe 1 × 2.5 mm ² 3C+E TPS cable 1 × CAT6 cable	BOSS FireMastic-HPE™	-	Ø100 mm
	L	DN32 mm galvanised sprinkler pipe	BOSS FireMastic-300™	-	Ø60 mm
	M	6 × 2.5 mm ² 2C+E TPS cables	BOSS FireMastic-HPE™	-	Ø57 mm
	N	4 × ELV extra low voltage alarm cables (2 core round)	BOSS FireMastic-HPE™	-	Ø20 mm
	O	Ø20 mm PEXa pipe	BOSS FireMastic-HPE™	-	Ø60 mm
	P	1 × 3/8 + 3/4 FR paircoil w/ 19 mm insulation 1 × DN32 type B copper pipe with Ø32 mm SUpaCell pipe lagging (25 mm wall thickness) 1 × 3/8 + 5/8 FR paircoil w/ 13 mm insulation	BOSS FireMastic-HPE™	-	Ø152 mm
	Q	Ø32 mm cPVC pipe	BOSS FireMastic-HPE™	-	Ø83 mm
	R	1 × 16 mm ² 2C+E cable	BOSS FireMastic-HPE™	-	Ø40 mm
Instrumentation	The test report states that the instrumentation was in accordance with AS 1530.4:2014.				

The test specimen achieved the following results – see Table 72

Table 72 Results summary for this test report

Penetration system	Criteria	Results	Fire resistance level (FRL)
A	Structural adequacy	Not applicable	-/120/90
	Integrity	No failure at 121 minutes	
	Insulation	Failure at 107 minutes	
B	Structural adequacy	Not applicable	-/120/120

Penetration system	Criteria	Results	Fire resistance level (FRL)
	Integrity	No failure at 121 minutes	
	Insulation	No failure at 121 minutes	
C	Structural adequacy	Not applicable	-/120/120
	Integrity	No failure at 121 minutes	
	Insulation	No failure at 121 minutes	
D	Structural adequacy	Not applicable	-/120/120
	Integrity	No failure at 121 minutes	
	Insulation	No failure at 121 minutes	
E	Structural adequacy	Not applicable	-/120/60
	Integrity	No failure at 121 minutes	
	Insulation	Failure at 84 minutes	
F	Structural adequacy	Not applicable	-/120/120
	Integrity	No failure at 121 minutes	
	Insulation	No failure at 121 minutes	
G	Structural adequacy	Not applicable	-/120/120
	Integrity	No failure at 121 minutes	
	Insulation	No failure at 121 minutes	
H	Structural adequacy	Not applicable	-/120/60
	Integrity	No failure at 121 minutes	
	Insulation	Failure at 86 minutes	
I	Structural adequacy	Not applicable	-/120/120
	Integrity	No failure at 121 minutes	
	Insulation	No failure at 121 minutes	
J	Structural adequacy	Not applicable	-/120/120
	Integrity	No failure at 121 minutes	
	Insulation	No failure at 121 minutes	
K	Structural adequacy	Not applicable	-/120/90
	Integrity	No failure at 121 minutes	
	Insulation	Failure at 110 minutes	

Penetration system	Criteria	Results	Fire resistance level (FRL)
L	Structural adequacy	Not applicable	-/120/120
	Integrity	No failure at 121 minutes	
	Insulation	No failure at 121 minutes	
M	Structural adequacy	Not applicable	-/120/120
	Integrity	No failure at 121 minutes	
	Insulation	No failure at 121 minutes	
N	Structural adequacy	Not applicable	-/120/90
	Integrity	No failure at 121 minutes	
	Insulation	Failure at 111 minutes	
O	Structural adequacy	Not applicable	-/120/120
	Integrity	No failure at 121 minutes	
	Insulation	No failure at 121 minutes	
P	Structural adequacy	Not applicable	-/120/120
	Integrity	No failure at 121 minutes	
	Insulation	No failure at 121 minutes	
Q	Structural adequacy	Not applicable	-/120/90
	Integrity	No failure at 121 minutes	
	Insulation	Failure at 114 minutes	
R	Structural adequacy	Not applicable	-/120/120
	Integrity	No failure at 121 minutes	
	Insulation	No failure at 121 minutes	

A.6 Test report – FSP 2084

Table 73 Information about test report

Item	Information about test report
Report sponsor	Knauf Plasterboard Pty Limited
Test laboratory	Infrastructure Technologies, 14 Julius Avenue, North Ryde, NSW 2113.
Test date	The fire resistance test was done on 12 February 2020.
Test standards	The test was done in accordance with AS 4072.1:2005.
Variation to test standards	None
General description of tested specimen	The specimens consisted of a PE-Xa Rehau Rautitan pipe, a PVC pipe, a 3-piece tap faucet and a SHS support arm penetrating the unexposed face of a plasterboard wall protected by various fire stopping systems. The penetrated wall consisted of a single layer of 13 mm thick Fireshield plasterboard on each side of 92 mm 0.55 BMT C-studs to form a 118 mm thick wall system. The wall cavity was filled with 75 mm thick Knauf Earthwool (density of 11 kg/m ³). The Knauf wall system (KSW310) has an established FRL of -/60/60, as detailed in BRANZ reports FAR 3210 and FAR 3230.
Instrumentation	The test report states that the instrumentation was in accordance with AS 4072.1:2005.

The test specimen achieved the following results – see Table 74.

Table 74 Results summary for this test report

Penetration system/ linear joint seal	Criteria	Results
Specimen 1	Structural adequacy	-
	Integrity	91
	Insulation	91
Specimen 2	Structural adequacy	-
	Integrity	91
	Insulation	91
Specimen 3	Structural adequacy	-
	Integrity	91
	Insulation	91
Specimen 4	Structural adequacy	-
	Integrity	91
	Insulation	91

A.7 Test report – FRT180474.3

Table 75 Information about test report

Item	Information about test report
Report sponsor	Boss fire and safety
Test laboratory	Warringtonfire, 409-411 Hammond Road, Dandenong South VIC 3175 Australia
Test date	The fire resistance test was done on 17 January 2020.
Test standards	The test was done in accordance with AS 1530.4:2014.
Variation to test standards	None

Item	Information about test report																																												
General description of tested specimen	<p>The specimens comprised of 235 mm thick ceiling system penetrated by 10 services as listed below.</p> <table border="1" data-bbox="584 309 1382 1792"> <thead> <tr> <th data-bbox="584 309 746 412">Penetration system</th> <th data-bbox="753 309 1024 412">Service</th> <th data-bbox="1031 309 1241 412">Local fire-stopping protection</th> <th data-bbox="1248 309 1382 412">Aperture size (mm)</th> </tr> </thead> <tbody> <tr> <td data-bbox="584 421 746 510">A</td> <td data-bbox="753 421 1024 510"> <ul style="list-style-type: none"> 4 × TPS - 2.5mm² 2C+E cables </td> <td data-bbox="1031 421 1241 510">BOSS FireMastic 300 and BOSS FireMastic HPE</td> <td data-bbox="1248 421 1382 510">Ø44</td> </tr> <tr> <td data-bbox="584 519 746 586">B</td> <td data-bbox="753 519 1024 586"> <ul style="list-style-type: none"> 2 × TPS - 2.5mm² 2C+E cables </td> <td data-bbox="1031 519 1241 586">BOSS FireMastic 300</td> <td data-bbox="1248 519 1382 586">Ø16</td> </tr> <tr> <td data-bbox="584 595 746 663">C</td> <td data-bbox="753 595 1024 663"> <ul style="list-style-type: none"> 7 × Cat 6 cables </td> <td data-bbox="1031 595 1241 663">BOSS FireMastic 300</td> <td data-bbox="1248 595 1382 663">Ø44</td> </tr> <tr> <td data-bbox="584 672 746 810">D</td> <td data-bbox="753 672 1024 810"> <ul style="list-style-type: none"> 1 × 32 mm steel sprinkler pipe </td> <td data-bbox="1031 672 1241 810">Thermal defence wrap, BOSS UniWrap and BOSS FireMastic 300</td> <td data-bbox="1248 672 1382 810">Ø51</td> </tr> <tr> <td data-bbox="584 819 746 909">E</td> <td data-bbox="753 819 1024 909"> <ul style="list-style-type: none"> 3 × Main power cable 2C+E cables </td> <td data-bbox="1031 819 1241 909">BOSS FireMastic 300</td> <td data-bbox="1248 819 1382 909">Ø51</td> </tr> <tr> <td data-bbox="584 918 746 1214">F</td> <td data-bbox="753 918 1024 1214"> <ul style="list-style-type: none"> 10 × TPS - 2.5mm² 2C+E cables 10 × Cat 6 cables 1 × Paircoil FR 2 × Paircoils 1 × Copper pipe with Insulation 1 × 25 mm UPVC conduit </td> <td data-bbox="1031 918 1241 1214">BOSS Fire Transit Box BFB 150 and BOSS FireMastic 300</td> <td data-bbox="1248 918 1382 1214">170 mm wide × 170 mm long</td> </tr> <tr> <td data-bbox="584 1223 746 1312">G</td> <td data-bbox="753 1223 1024 1312"> <ul style="list-style-type: none"> 1 × 25 mm UPVC conduit </td> <td data-bbox="1031 1223 1241 1312">BOSS FireMastic 300 and BOSS FireMastic HPE</td> <td data-bbox="1248 1223 1382 1312">Ø63</td> </tr> <tr> <td data-bbox="584 1321 746 1438">H</td> <td data-bbox="753 1321 1024 1438"> <ul style="list-style-type: none"> 1 × 32 mm UPVC DWV pipe </td> <td data-bbox="1031 1321 1241 1438">BOSS FireMastic 300 and BOSS MaxiCollar 40 collar</td> <td data-bbox="1248 1321 1382 1438">Ø42</td> </tr> <tr> <td data-bbox="584 1447 746 1639">I</td> <td data-bbox="753 1447 1024 1639"> <ul style="list-style-type: none"> 1 × TPS - 2.5mm² 2C+E cable 1 × Cat 6 cable 1 × Paircoil FR 1 × 25 mm UPVC conduit </td> <td data-bbox="1031 1447 1241 1639">BOSS FireMastic 300, BOSS MaxiCollar 80 collar and BOSS FireMastic - HPE</td> <td data-bbox="1248 1447 1382 1639">Ø72</td> </tr> <tr> <td data-bbox="584 1648 746 1792">J</td> <td data-bbox="753 1648 1024 1792"> <ul style="list-style-type: none"> 2 × 25 mm UPVC conduits 2 × TPS - 2.5mm² 2C+E cables </td> <td data-bbox="1031 1648 1241 1792">BOSS FireMastic 300, BOSS MaxiCollar 65 collar and BOSS FireMastic - HPE</td> <td data-bbox="1248 1648 1382 1792">Ø51</td> </tr> </tbody> </table>	Penetration system	Service	Local fire-stopping protection	Aperture size (mm)	A	<ul style="list-style-type: none"> 4 × TPS - 2.5mm² 2C+E cables 	BOSS FireMastic 300 and BOSS FireMastic HPE	Ø44	B	<ul style="list-style-type: none"> 2 × TPS - 2.5mm² 2C+E cables 	BOSS FireMastic 300	Ø16	C	<ul style="list-style-type: none"> 7 × Cat 6 cables 	BOSS FireMastic 300	Ø44	D	<ul style="list-style-type: none"> 1 × 32 mm steel sprinkler pipe 	Thermal defence wrap, BOSS UniWrap and BOSS FireMastic 300	Ø51	E	<ul style="list-style-type: none"> 3 × Main power cable 2C+E cables 	BOSS FireMastic 300	Ø51	F	<ul style="list-style-type: none"> 10 × TPS - 2.5mm² 2C+E cables 10 × Cat 6 cables 1 × Paircoil FR 2 × Paircoils 1 × Copper pipe with Insulation 1 × 25 mm UPVC conduit 	BOSS Fire Transit Box BFB 150 and BOSS FireMastic 300	170 mm wide × 170 mm long	G	<ul style="list-style-type: none"> 1 × 25 mm UPVC conduit 	BOSS FireMastic 300 and BOSS FireMastic HPE	Ø63	H	<ul style="list-style-type: none"> 1 × 32 mm UPVC DWV pipe 	BOSS FireMastic 300 and BOSS MaxiCollar 40 collar	Ø42	I	<ul style="list-style-type: none"> 1 × TPS - 2.5mm² 2C+E cable 1 × Cat 6 cable 1 × Paircoil FR 1 × 25 mm UPVC conduit 	BOSS FireMastic 300, BOSS MaxiCollar 80 collar and BOSS FireMastic - HPE	Ø72	J	<ul style="list-style-type: none"> 2 × 25 mm UPVC conduits 2 × TPS - 2.5mm² 2C+E cables 	BOSS FireMastic 300, BOSS MaxiCollar 65 collar and BOSS FireMastic - HPE	Ø51
Penetration system	Service	Local fire-stopping protection	Aperture size (mm)																																										
A	<ul style="list-style-type: none"> 4 × TPS - 2.5mm² 2C+E cables 	BOSS FireMastic 300 and BOSS FireMastic HPE	Ø44																																										
B	<ul style="list-style-type: none"> 2 × TPS - 2.5mm² 2C+E cables 	BOSS FireMastic 300	Ø16																																										
C	<ul style="list-style-type: none"> 7 × Cat 6 cables 	BOSS FireMastic 300	Ø44																																										
D	<ul style="list-style-type: none"> 1 × 32 mm steel sprinkler pipe 	Thermal defence wrap, BOSS UniWrap and BOSS FireMastic 300	Ø51																																										
E	<ul style="list-style-type: none"> 3 × Main power cable 2C+E cables 	BOSS FireMastic 300	Ø51																																										
F	<ul style="list-style-type: none"> 10 × TPS - 2.5mm² 2C+E cables 10 × Cat 6 cables 1 × Paircoil FR 2 × Paircoils 1 × Copper pipe with Insulation 1 × 25 mm UPVC conduit 	BOSS Fire Transit Box BFB 150 and BOSS FireMastic 300	170 mm wide × 170 mm long																																										
G	<ul style="list-style-type: none"> 1 × 25 mm UPVC conduit 	BOSS FireMastic 300 and BOSS FireMastic HPE	Ø63																																										
H	<ul style="list-style-type: none"> 1 × 32 mm UPVC DWV pipe 	BOSS FireMastic 300 and BOSS MaxiCollar 40 collar	Ø42																																										
I	<ul style="list-style-type: none"> 1 × TPS - 2.5mm² 2C+E cable 1 × Cat 6 cable 1 × Paircoil FR 1 × 25 mm UPVC conduit 	BOSS FireMastic 300, BOSS MaxiCollar 80 collar and BOSS FireMastic - HPE	Ø72																																										
J	<ul style="list-style-type: none"> 2 × 25 mm UPVC conduits 2 × TPS - 2.5mm² 2C+E cables 	BOSS FireMastic 300, BOSS MaxiCollar 65 collar and BOSS FireMastic - HPE	Ø51																																										
Instrumentation	The test report states that the instrumentation was in accordance with AS 1530.4:2014																																												

The test specimen achieved the following results – see Table 76.

Table 76 Results summary for this test report

Penetration system	Criteria	Results	Fire resistance level (FRL)
A	Structural adequacy	Not applicable	-/90/90
	Integrity	No failure at 91 minutes	
	Insulation	No failure at 91 minutes	
	RISF	Failure at 55 minutes	
B	Structural adequacy	Not applicable	-/90/90
	Integrity	No failure at 91 minutes	
	Insulation	No failure at 91 minutes	
	RISF	Failure at 36 minutes	
C	Structural adequacy	Not applicable	-/90/90
	Integrity	No failure at 91 minutes	
	Insulation	No failure at 91 minutes	
	RISF	Failure at 60 minutes	
D	Structural adequacy	Not applicable	-/90/90
	Integrity	No failure at 91 minutes	
	Insulation	No failure at 91 minutes	
	RISF	Failure at 35 minutes	
E	Structural adequacy	Not applicable	-/90/90
	Integrity	No failure at 91 minutes	
	Insulation	No failure at 91 minutes	
	RISF	Failure at 54 minutes	
F	Structural adequacy	Not applicable	-/90/60
	Integrity	No failure at 91 minutes	

Penetration system	Criteria	Results	Fire resistance level (FRL)
G	Insulation	Failure at 75 minutes	-/90/90
	RISF	Failure at 40 minutes	
	Structural adequacy	Not applicable	
	Integrity	No failure at 91 minutes	
H	Insulation	No failure at 91 minutes	-/90/90
	RISF	Failure at 55 minutes	
	Structural adequacy	Not applicable	
	Integrity	No failure at 91 minutes	
I	Insulation	No failure at 91 minutes	-/90/90
	RISF	Failure at 48 minutes	
	Structural adequacy	Not applicable	
	Integrity	No failure at 91 minutes	
J	Insulation	No failure at 91 minutes	-/90/90
	RISF	Failure at 53 minutes	
	Structural adequacy	Not applicable	
	Integrity	No failure at 91 minutes	
	Insulation	No failure at 91 minutes	
	RISF	Failure at 24 minutes	

A.8 Test report – FRT210330 R1.1

Table 77 Information about test report

Item	Information about test report
Report sponsor	Boss Products (Australia) Pty Ltd
Test laboratory	Warringtonfire, 409-411 Hammond Road, Dandenong South VIC 3175 Australia
Test date	The fire resistance test was done on 24 June 2022.
Test standards	The test was done in accordance with AS 1530.4:2014.

Item	Information about test report
Variation to test standards	None

General description of tested specimen	The specimens comprised of a CLT wall system of dimensions 1200 mm wide by 1200 mm high by 130 mm thick penetrated by 9 services as listed below. The tested system was restrained on all edges.			
	Penetration system	Service	Local fire-stopping protection	Aperture size (mm)
	A	DN 50 mm steel sprinkler pipe	BOSS FireMastic-300	Ø73 mm
	B	<ul style="list-style-type: none"> • 1 × 48.4 mm steel sprinkler pipe • 2 × 22 mm stainless steel pipes with 20 mm Thermobreak 9705 lagging • 2 × 25 mm Kelox plus pipes • 1 × 25 mm condensation drain pipe • 1 × 16 mm² 3C+E cable • 1 × 50 mm² 2C+E cable • 3 × fire alarm cables • 4 × Cat 6 cables • 1 × 2.5 mm² 2C+E TPS cable • 1 × 2.5 mm² 3C+E TPS cable • 2 × RG6 Coax cables • 1 × Fig 8 cable • 1 × Security cable 	<ul style="list-style-type: none"> • BOSS FyreBox™ – BFB-300 • BOSS FireMastic-300 • BOSS Thermal defence wrap 	320 mm wide × 170 mm high
	C	16 mm ² 3C+E cable	BOSS FireMastic-HPE	Ø40 mm
	D	<ul style="list-style-type: none"> • 2 × CAT 6 cables • 2 × RG6 Coax cables • 1 × Security cable • 1 × Fig 8 cable • 2 × Fire alarm cables 	BOSS FireMastic-HPE	Ø40 mm
	E	20 mm Pex-Xa pipe	BOSS FireMastic-HPE	Ø60 mm
	F	20 mm Pex/Al/Pex pipe	BOSS FireMastic-HPE	Ø60 mm
	G	25 mm Kelox plus pipe	BOSS FireMastic-HPE	Ø83 mm
	H	<ul style="list-style-type: none"> • 1 × 3/8" × 3/4" Pair coil w/ 19 mm insulation • 1 × 20 mm condensation drain pipe 	BOSS FireMastic-HPE	Ø121 mm

Item	Information about test report			
		<ul style="list-style-type: none"> 1 × 2.5 mm² 3C+E TPS cable 1 × 2.5 mm² 2C+E TPS cable 1 × Instrolex control cable 		
	I	<ul style="list-style-type: none"> 1 × 32 mm conduit 6 × 2.5 mm² 2C+E TPS cables inside the 32 mm conduit 	BOSS FireMastic-HPE	Ø70 mm
Instrumentation	The test report states that the instrumentation was in accordance with AS 1530.4:2014.			

The test specimen achieved the following results – see Table 78.

Table 78 Results summary for this test report

Penetration system	Criteria	Results	Fire resistance level (FRL)
A	Structural adequacy	Not applicable	-/90/60
	Integrity	No failure at 100 minutes	
	Insulation	Failure at 61 minutes	
B	Structural adequacy	Not applicable	-/90/90
	Integrity	No failure at 100 minutes	
	Insulation	Failure at 94 minutes	
C	Structural adequacy	Not applicable	-/90/90
	Integrity	No failure at 100 minutes	
	Insulation	No failure at 100 minutes	
D	Structural adequacy	Not applicable	-/90/90
	Integrity	No failure at 100 minutes	
	Insulation	Failure at 93 minutes	
E	Structural adequacy	Not applicable	-/90/90
	Integrity	No failure at 100 minutes	
	Insulation	No failure at 100 minutes	
F	Structural adequacy	Not applicable	-/90/60
	Integrity	No failure at 100 minutes	
	Insulation	Failure at 65 minutes	
G	Structural adequacy	Not applicable	-/90/90
	Integrity	No failure at 100 minutes	
	Insulation	No failure at 100 minutes	
H	Structural adequacy	Not applicable	-/90/90
	Integrity	No failure at 100 minutes	
	Insulation	No failure at 100 minutes	
I	Structural adequacy	Not applicable	-/90/90
	Integrity	No failure at 100 minutes	
	Insulation	No failure at 100 minutes	

A.9 Test report – FRT220049

Table 79 Information about test report

Item	Information about test report
Report sponsor	Boss Products (Australia) Pty Ltd
Test laboratory	Warringtonfire, 409-411 Hammond Road, Dandenong South VIC 3175 Australia
Test date	The fire resistance test was done on 27 June 2022.
Test standards	The test was done in accordance with AS 1530.4:2014.
Variation to test standards	None

General description of tested specimen	The specimens comprised of a 150 mm thick floor system penetrated by 10 services as listed below.			
	Penetration system	Service	Local fire-stopping protection	Aperture size (mm)
	A	<ul style="list-style-type: none"> 1 1/8" copper pipe with 25 mm thick E-Flex ST lagging 7/8" copper pipe with 25 mm thick E-Flex ST lagging DN 18 copper pipe with 19 mm thick E-Flex ST lagging 20 mm condensation drain pipe 2.5 mm² 3C+E TPS cable Fire alarm cable Instrolex control cable 	BOSS FireMastic-HPE	Ø150 mm
	B	20 mm Pex-Xa pipe	BOSS FireMastic-HPE	Ø40 mm
	C	<ul style="list-style-type: none"> 16 mm² 2C+E cable 2.5 mm² 2C+E TPS cable 2.5 mm² 3C+E TPS cable 20 mm Pex-A pipe 20 mm Pex/Al/Pex pipe 3/8" × 3/4" Pair coil w/ 19 mm insulation DN 20 mm conduit DN 25 mm conduit Cable bundles <ul style="list-style-type: none"> -CAT 6 cable -RG6 Coax cable -Fire alarm cable -Fig 8 cable -Security cable 	<ul style="list-style-type: none"> BOSS FyreBox™ – BFB-150 BOSS FireMastic-300 	180 mm wide × 180 mm long
	D	DN 32 mm UPVC pipe	BOSS FireMastic-HPE	Ø50 mm
	E	20 mm Pex/Al/Pex pipe	BOSS FireMastic-HPE	Ø40 mm
	F	6 × 2.5 mm ² TPS cable	BOSS FireMastic-HPE	Ø30 mm
G	<ul style="list-style-type: none"> 4 × RG6 Coax cable 4 × CAT 6 cable 2 × Fire alarm cable Security cable 	BOSS FireMastic-HPE	Ø50 mm	

Item	Information about test report			
	H	<ul style="list-style-type: none"> 20 mm Pex/Al/Pex pipe 32 mm Pex/Al/Pex pipe DN 50 mm PPR pipe DN 60 mm cPVC pipe DN 25 mm UPVC pipe 32 mm Pex-Xa pipe 20 mm Pex-Xa pipe 	<ul style="list-style-type: none"> BOSS FyreBox™ – BFB-450 BOSS FireMastic-300 BOSS Thermal defence wrap 	465 mm wide × 123 mm long
	I	<ul style="list-style-type: none"> 3/8" × 3/4" Pair coil w/ 19 mm insulation 2.5 mm² 3C+E TPS cable Cat 6 cable Instrolex control cable 2.5 mm² 2C+E TPS cable 20 mm condensation drain pipe 	BOSS FireMastic-HPE	Ø100 mm
	J	2 × DN 20 mm conduit	BOSS FireMastic-HPE	Ø50 mm
Instrumentation	The test report states that the instrumentation was in accordance with AS 1530.4:2014.			

The test specimen achieved the following results – see Table 80.

Table 80 Results summary for this test report

Penetration system	Criteria	Results	Fire resistance level (FRL)
A	Structural adequacy	Not applicable	-/240/120
	Integrity	No failure at 241 minutes	
	Insulation	Failure at 124 minutes	
B	Structural adequacy	Not applicable	-/240/240
	Integrity	No failure at 241 minutes	
	Insulation	No failure at 241 minutes	
C	Structural adequacy	Not applicable	-/240/120
	Integrity	No failure at 241 minutes	
	Insulation	Failure at 177 minutes	
D	Structural adequacy	Not applicable	-/240/240
	Integrity	No failure at 241 minutes	
	Insulation	No failure at 241 minutes	
E	Structural adequacy	Not applicable	-/240/240
	Integrity	No failure at 241 minutes	
	Insulation	No failure at 241 minutes	

Penetration system	Criteria	Results	Fire resistance level (FRL)
F	Structural adequacy	Not applicable	-/240/240
	Integrity	No failure at 241 minutes	
	Insulation	No failure at 241 minutes	
G	Structural adequacy	Not applicable	-/240/240
	Integrity	No failure at 241 minutes	
	Insulation	Failure at 241 minutes	
H	Structural adequacy	Not applicable	-/240/180
	Integrity	No failure at 241 minutes	
	Insulation	Failure at 227 minutes	
I	Structural adequacy	Not applicable	-/240/240
	Integrity	No failure at 241 minutes	
	Insulation	No failure at 241 minutes	
J	Structural adequacy	Not applicable	-/240/240
	Integrity	No failure at 241 minutes	
	Insulation	No failure at 241 minutes	

A.10 Test report – FRT220141 R1.1

Table 81 Information about test report

Item	Information about test report
Report sponsor	Boss Products (Australia) Pty Ltd
Test laboratory	Warringtonfire, 409-411 Hammond Road, Dandenong South VIC 3175 Australia
Test date	The fire resistance test was done on 15 July 2022.
Test standards	The test was done in accordance with AS 1530.4:2014.
Variation to test standards	None

Item	Information about test report																																								
General description of tested specimen	<p>The specimens comprised of a 75 mm thick AAC panel wall penetrated by 10 services as listed below. The tested system is restrained on top and bottom edges.</p> <table border="1" data-bbox="528 338 1385 1529"> <thead> <tr> <th data-bbox="528 338 692 439">Penetration system</th> <th data-bbox="692 338 938 439">Service</th> <th data-bbox="938 338 1233 439">Local fire-stopping protection</th> <th data-bbox="1233 338 1385 439">Local aperture size (mm)</th> </tr> </thead> <tbody> <tr> <td data-bbox="528 439 692 633">A</td> <td data-bbox="692 439 938 633"> <ul style="list-style-type: none"> 3/8" × 5/8" Pair coil 2C+E 2.5 mm² TPS cable </td> <td data-bbox="938 439 1233 633"> <ul style="list-style-type: none"> BOSS FireMastic-HPE™ 16 mm CSR GYPROCK Fyrchek plasterboard on unexposed side </td> <td data-bbox="1233 439 1385 633">Ø 80 mm</td> </tr> <tr> <td data-bbox="528 633 692 707">B</td> <td data-bbox="692 633 938 707">4 × 0.75 mm² 2C Fire alarm cables</td> <td data-bbox="938 633 1233 707"> <ul style="list-style-type: none"> BOSS FireMastic HPE </td> <td data-bbox="1233 633 1385 707">Ø 30 mm</td> </tr> <tr> <td data-bbox="528 707 692 902">C</td> <td data-bbox="692 707 938 902"> <ul style="list-style-type: none"> 3/8" × 5/8" Pair coil 2C+E 2.5 mm² TPS cable </td> <td data-bbox="938 707 1233 902"> <ul style="list-style-type: none"> BOSS FireMastic-HPE™ 16 mm CSR GYPROCK Fyrchek plasterboard on exposed side </td> <td data-bbox="1233 707 1385 902">Ø 80 mm</td> </tr> <tr> <td data-bbox="528 902 692 1171">D</td> <td data-bbox="692 902 938 1171"> <ul style="list-style-type: none"> 3/8" × 5/8" Pair coil 20 mm condensation pipe 2 × 2C+E 2.5 mm² TPS cables 2 × Cat 6 cable </td> <td data-bbox="938 902 1233 1171">BOSS FireMastic-HPE™</td> <td data-bbox="1233 902 1385 1171">Ø 80 mm</td> </tr> <tr> <td data-bbox="528 1171 692 1245">E</td> <td data-bbox="692 1171 938 1245">25 mm Pex-A pipe</td> <td data-bbox="938 1171 1233 1245">BOSS FireMastic-HPE™</td> <td data-bbox="1233 1171 1385 1245">Ø 48 mm</td> </tr> <tr> <td data-bbox="528 1245 692 1319">F</td> <td data-bbox="692 1245 938 1319">25 mm condensation pipe</td> <td data-bbox="938 1245 1233 1319">BOSS FireMastic-HPE™</td> <td data-bbox="1233 1245 1385 1319">Ø 40 mm</td> </tr> <tr> <td data-bbox="528 1319 692 1393">G</td> <td data-bbox="692 1319 938 1393">25 mm Pex/Al/Pex pipe</td> <td data-bbox="938 1319 1233 1393">BOSS FireMastic-HPE™</td> <td data-bbox="1233 1319 1385 1393">Ø 48 mm</td> </tr> <tr> <td data-bbox="528 1393 692 1467">H</td> <td data-bbox="692 1393 938 1467">20 mm Pex/Al/Pex pipe</td> <td data-bbox="938 1393 1233 1467">BOSS FireMastic-HPE™</td> <td data-bbox="1233 1393 1385 1467">Ø 40 mm</td> </tr> <tr> <td data-bbox="528 1467 692 1529">I</td> <td data-bbox="692 1467 938 1529">20 mm Pex/Al/Pex pipe</td> <td data-bbox="938 1467 1233 1529">BOSS FireMastic-HPE™</td> <td data-bbox="1233 1467 1385 1529">Ø 40 mm</td> </tr> </tbody> </table>	Penetration system	Service	Local fire-stopping protection	Local aperture size (mm)	A	<ul style="list-style-type: none"> 3/8" × 5/8" Pair coil 2C+E 2.5 mm² TPS cable 	<ul style="list-style-type: none"> BOSS FireMastic-HPE™ 16 mm CSR GYPROCK Fyrchek plasterboard on unexposed side 	Ø 80 mm	B	4 × 0.75 mm ² 2C Fire alarm cables	<ul style="list-style-type: none"> BOSS FireMastic HPE 	Ø 30 mm	C	<ul style="list-style-type: none"> 3/8" × 5/8" Pair coil 2C+E 2.5 mm² TPS cable 	<ul style="list-style-type: none"> BOSS FireMastic-HPE™ 16 mm CSR GYPROCK Fyrchek plasterboard on exposed side 	Ø 80 mm	D	<ul style="list-style-type: none"> 3/8" × 5/8" Pair coil 20 mm condensation pipe 2 × 2C+E 2.5 mm² TPS cables 2 × Cat 6 cable 	BOSS FireMastic-HPE™	Ø 80 mm	E	25 mm Pex-A pipe	BOSS FireMastic-HPE™	Ø 48 mm	F	25 mm condensation pipe	BOSS FireMastic-HPE™	Ø 40 mm	G	25 mm Pex/Al/Pex pipe	BOSS FireMastic-HPE™	Ø 48 mm	H	20 mm Pex/Al/Pex pipe	BOSS FireMastic-HPE™	Ø 40 mm	I	20 mm Pex/Al/Pex pipe	BOSS FireMastic-HPE™	Ø 40 mm
Penetration system	Service	Local fire-stopping protection	Local aperture size (mm)																																						
A	<ul style="list-style-type: none"> 3/8" × 5/8" Pair coil 2C+E 2.5 mm² TPS cable 	<ul style="list-style-type: none"> BOSS FireMastic-HPE™ 16 mm CSR GYPROCK Fyrchek plasterboard on unexposed side 	Ø 80 mm																																						
B	4 × 0.75 mm ² 2C Fire alarm cables	<ul style="list-style-type: none"> BOSS FireMastic HPE 	Ø 30 mm																																						
C	<ul style="list-style-type: none"> 3/8" × 5/8" Pair coil 2C+E 2.5 mm² TPS cable 	<ul style="list-style-type: none"> BOSS FireMastic-HPE™ 16 mm CSR GYPROCK Fyrchek plasterboard on exposed side 	Ø 80 mm																																						
D	<ul style="list-style-type: none"> 3/8" × 5/8" Pair coil 20 mm condensation pipe 2 × 2C+E 2.5 mm² TPS cables 2 × Cat 6 cable 	BOSS FireMastic-HPE™	Ø 80 mm																																						
E	25 mm Pex-A pipe	BOSS FireMastic-HPE™	Ø 48 mm																																						
F	25 mm condensation pipe	BOSS FireMastic-HPE™	Ø 40 mm																																						
G	25 mm Pex/Al/Pex pipe	BOSS FireMastic-HPE™	Ø 48 mm																																						
H	20 mm Pex/Al/Pex pipe	BOSS FireMastic-HPE™	Ø 40 mm																																						
I	20 mm Pex/Al/Pex pipe	BOSS FireMastic-HPE™	Ø 40 mm																																						
Instrumentation	The test report states that the instrumentation was in accordance with AS 1530.4:2014.																																								

The test specimen achieved the following results – see Table 82.

Table 82 Results summary for this test report

Penetration system	Criteria	Results	Fire resistance level (FRL)
A	Structural adequacy	Not applicable	-/120/120
	Integrity	No failure at 121 minutes	
	Insulation	No failure at 121 minutes	
B	Structural adequacy	Not applicable	-/120/120
	Integrity	No failure at 121 minutes	

Penetration system	Criteria	Results	Fire resistance level (FRL)
	Insulation	No failure at 121 minutes	
C	Structural adequacy	Not applicable	-120/120
	Integrity	No failure at 121 minutes	
	Insulation	No failure at 121 minutes	
D	Structural adequacy	Not applicable	-120/120
	Integrity	No failure at 121 minutes	
	Insulation	No failure at 121 minutes	
E	Structural adequacy	Not applicable	-120/120
	Integrity	No failure at 121 minutes	
	Insulation	No failure at 121 minutes	
F	Structural adequacy	Not applicable	-120/120
	Integrity	No failure at 121 minutes	
	Insulation	No failure at 121 minutes	
G	Structural adequacy	Not applicable	-120/120
	Integrity	No failure at 121 minutes	
	Insulation	No failure at 121 minutes	
H	Structural adequacy	Not applicable	-120/120
	Integrity	No failure at 121 minutes	
	Insulation	No failure at 121 minutes	
I	Structural adequacy	Not applicable	-120/120
	Integrity	No failure at 121 minutes	
	Insulation	No failure at 121 minutes	

A.11 Test report – FRT180472.2

Table 83 Information about test report

Item	Information about test report
Report sponsor	Boss Products (Australia) Pty Ltd
Test laboratory	Warringtonfire, 409-411 Hammond Road, Dandenong South VIC 3175 Australia
Test date	The fire resistance test was done on 8 March 2019
Test standards	The test was done in accordance with AS 1530.4:2014.
Variation to test standards	None

Item	Information about test report																																																							
General description of tested specimen	The specimens consisted of 116 mm thick plasterboard wall system clad with two layer of fire rated plasterboard on either side penetrated by 10 penetration systems as listed below.																																																							
	<table border="1"> <thead> <tr> <th>Penetration system</th> <th>Service</th> <th>Primary local fire-stopping protection</th> <th>Second local fire-stopping protection</th> <th>Aperture size (mm)</th> </tr> </thead> <tbody> <tr> <td>A</td> <td>50 mm copper pipe with lagging</td> <td>BOSS 100 mm MaxiCollars™</td> <td>P40 Mark Wrap with FireMastic - 300</td> <td>Ø115</td> </tr> <tr> <td>B</td> <td>Bundle of Electric cable</td> <td>FireMastic - HPE</td> <td>-</td> <td>Ø70</td> </tr> <tr> <td>C</td> <td>100 mm UPVC sandwich core pipe</td> <td>BOSS UniWrap® in metal sleeve</td> <td>FireMastic - 300</td> <td>Ø130</td> </tr> <tr> <td>D</td> <td>150 mm copper pipe</td> <td>FireMastic - 300</td> <td>-</td> <td>Ø170</td> </tr> <tr> <td>E</td> <td>40 mm UPVC pipe</td> <td>BOSS UniWrap® in metal sleeve</td> <td>FireMastic - 300</td> <td>Ø60</td> </tr> <tr> <td>F1</td> <td>Fire rated GPO (unexposed side)</td> <td>UniWrap intumescent in wallbox</td> <td>-</td> <td>99 × 55</td> </tr> <tr> <td>F2</td> <td>Fire rated GPO (exposed side)</td> <td>UniWrap intumescent in wallbox</td> <td>-</td> <td>99 × 55</td> </tr> <tr> <td>G</td> <td>50 mm Galv Sprinkler pipe</td> <td>FireMastic - 300</td> <td>-</td> <td>Ø80</td> </tr> <tr> <td>H</td> <td>80 mm UPVC pipe</td> <td>BOSS UniWrap® in metal sleeve</td> <td>FireMastic - 300</td> <td>Ø102</td> </tr> <tr> <td>I</td> <td>50 mmUPVC pipe</td> <td>BOSS UniWrap® in metal sleeve</td> <td>FireMastic - 300</td> <td>Ø70</td> </tr> </tbody> </table>	Penetration system	Service	Primary local fire-stopping protection	Second local fire-stopping protection	Aperture size (mm)	A	50 mm copper pipe with lagging	BOSS 100 mm MaxiCollars™	P40 Mark Wrap with FireMastic - 300	Ø115	B	Bundle of Electric cable	FireMastic - HPE	-	Ø70	C	100 mm UPVC sandwich core pipe	BOSS UniWrap® in metal sleeve	FireMastic - 300	Ø130	D	150 mm copper pipe	FireMastic - 300	-	Ø170	E	40 mm UPVC pipe	BOSS UniWrap® in metal sleeve	FireMastic - 300	Ø60	F1	Fire rated GPO (unexposed side)	UniWrap intumescent in wallbox	-	99 × 55	F2	Fire rated GPO (exposed side)	UniWrap intumescent in wallbox	-	99 × 55	G	50 mm Galv Sprinkler pipe	FireMastic - 300	-	Ø80	H	80 mm UPVC pipe	BOSS UniWrap® in metal sleeve	FireMastic - 300	Ø102	I	50 mmUPVC pipe	BOSS UniWrap® in metal sleeve	FireMastic - 300	Ø70
	Penetration system	Service	Primary local fire-stopping protection	Second local fire-stopping protection	Aperture size (mm)																																																			
	A	50 mm copper pipe with lagging	BOSS 100 mm MaxiCollars™	P40 Mark Wrap with FireMastic - 300	Ø115																																																			
	B	Bundle of Electric cable	FireMastic - HPE	-	Ø70																																																			
	C	100 mm UPVC sandwich core pipe	BOSS UniWrap® in metal sleeve	FireMastic - 300	Ø130																																																			
	D	150 mm copper pipe	FireMastic - 300	-	Ø170																																																			
	E	40 mm UPVC pipe	BOSS UniWrap® in metal sleeve	FireMastic - 300	Ø60																																																			
	F1	Fire rated GPO (unexposed side)	UniWrap intumescent in wallbox	-	99 × 55																																																			
	F2	Fire rated GPO (exposed side)	UniWrap intumescent in wallbox	-	99 × 55																																																			
G	50 mm Galv Sprinkler pipe	FireMastic - 300	-	Ø80																																																				
H	80 mm UPVC pipe	BOSS UniWrap® in metal sleeve	FireMastic - 300	Ø102																																																				
I	50 mmUPVC pipe	BOSS UniWrap® in metal sleeve	FireMastic - 300	Ø70																																																				
Instrumentation	The test report states that the instrumentation was in accordance with AS 1530.4:2014.																																																							

The test specimen achieved the following results – see Table 84.

Table 84 Results summary for this test report

Penetration system	Service	Primary local fire-stopping protection	Second local fire-stopping protection	Aperture size (mm)	FRL
A	50 mm copper pipe with lagging	BOSS 100 mm MaxiCollars™	P40-Mak Wrap with FireMastic - 300	Ø115	-/120/90
B	Bundle of Electric cable	FireMastic -HPE	-	Ø70	-/120/120

C	100 mm UPVC sandwich core pipe	BOSS UniWrap® in metal sleeve	FireMastic - 300	Ø130	-/0/0
D	150 mm copper pipe	FireMastic - 300	-	Ø170	-/120/0
E	40 mm UPVC pipe	BOSS UniWrap® in metal sleeve	FireMastic - 300	Ø60	-/120/120
F1	Fire rated GPO (unexposed side)	UniWrap intumescent in wallbox	-	99 × 55	-/120/120
F2	Fire rated GPO (exposed side)	UniWrap intumescent in wallbox	-	99 × 55	-/120/90
G	50 mm Galv Sprinkler pipe	FireMastic - 300	-	Ø80	-/120/120
H	80 mm UPVC pipe	BOSS UniWrap® in metal sleeve	FireMastic - 300	Ø102	-/120/0
I	50 mmUPVC pipe	BOSS UniWrap® in metal sleeve	FireMastic - 300	Ø70	-/120/120

A.12 Test report – FRT180137

Table 85 Information about test report

Item	Information about test report
Report sponsor	Boss Products (Australia) Pty Ltd
Test laboratory	Warringtonfire, 409-411 Hammond Road, Dandenong South VIC 3175 Australia
Test date	The fire resistance test was done on 7 March 2019
Test standards	The test was done in accordance with AS 1530.4:2014.
Variation to test standards	None

Item	Information about test report				
<p>General description of tested specimen</p>	<p>The specimens consisted of 70 mm – 130 mm thick composite floor system penetrated by 9 penetration systems as listed below. The tested system is restrained on all edges.</p>				
	Penetration system	Service	Primary fire-stopping protection	Second fire-stopping protection	Aperture size (mm)
	A	Bundle of TPS cables	BOSS Batt	BOSS FireMastic - HPE™	Ø76mm
	B	32mm PEX-A pipe	-	BOSS FireMastic – HPE™	Ø78mm
	C	Pair Coil pipe 25 mm UPVC Drain pipe	BOSS Batt	BOSS FireMastic – HPE™	Ø100 mm
	D	100 mm UPVC DWV pipe	BOSS Batt	Boss MaxiCollar™ BOSS FireMastic – 300™	Ø127mm
	E	Pair Coil 16mm + 10 mm lagged copper pipe 25 mm UPVC conduit 9 × TPS cables bundle 15 × CAT6 cable bundle 15 × Firesense cable bundle 32mm galvanised sprinkler pipe 32mm copper	BOSS Fire box	BOSS P40-MAK Wrap BOSS FireMastic - 300™	160 mm ×170 mm
	F	32mm copper pipe	-	BOSS FireMastic – 300™	Ø34mm
	G	100 mm UPVC DWV pipe	-	BOSS Drop in Collar BOSS FireMastic – 300™	Ø155mm
	H	75mm HDPE pipe	BOSS Batt	BOSS FireMastic – 300™ BOSS MaxiCollar™	Ø92mm
	I	25 mm UPVC conduit pipe	BOSS Batt	BOSS MaxiCollar™ BOSS FireMastic - 300™	Ø35mm

Item	Information about test report
Instrumentation	The test report states that the instrumentation was in accordance with AS 1530.4:2014.

The test specimen achieved the following results – see Table 86

Table 86 Results summary for this test report

Penetration system	Service	Primary fire-stopping protection	Second fire-stopping protection	Aperture size (mm)	FRL
A	Bundle of TPS cables	BOSS Batt	BOSS FireMastic - HPE™	Ø76mm	-/120/120
B	32mm PEX-A pipe	-	BOSS FireMastic – HPE™	Ø78mm	-/120/0
C	Pair Coil pipe 25 mm UPVC Drain pipe	BOSS Batt	BOSS FireMastic – HPE™	Ø100 mm	-/120/120
D	100 mm UPVC DWV pipe	BOSS Batt	Boss MaxiCollar™ BOSS FireMastic – 300™	Ø127mm	-/120/120
E	Pair Coil 16mm + 10 mm lagged copper pipe 25 mm UPVC conduit 9 × TPS cables bundle 15 × CAT6 cable bundle 15 × Firesense cable bundle 32mm galvanised sprinkler pipe 32mm copper	BOSS Fire box	BOSS P40-MAK Wrap BOSS FireMastic - 300™	160 mm × 170 mm	-/120/60
F	32mm copper pipe	-	BOSS FireMastic – 300™	Ø34mm	-/120/30
G	100 mm UPVC DWV pipe	-	BOSS Drop in collar	Ø155mm	-/120/90

			BOSS FireMastic – 300™		
H	75mm HDPE pipe	BOSS Batt	BOSS FireMastic – 300™	Ø92mm	-/120/120
			BOSS MaxiCollar™		
I	25 mm UPVC conduit pipe	BOSS Batt	BOSS MaxiCollar™	Ø35mm	-/120/120
			BOSS FireMastic - 300™		

A.13 Test report – FRT180473 R1.0

Table 87 Information about test report

Item	Information about test report
Report sponsor	Boss Products (Australia) Pty Ltd
Test laboratory	Warringtonfire, 409-411 Hammond Road, Dandenong South VIC 3175 Australia
Test date	The fire resistance test was done on 12 March 2019
Test standards	The test was done in accordance with AS 1530.4:2014.
Variation to test standards	None

General description of tested specimen	The specimens consisted of 75 mm thick Hebel power panel penetrated by 13 services as listed below. The tested system is restrained on all edges.				
	Penetration system	Service	Local fire-stopping protection	Main fire-stopping protection	Aperture size (mm)
	A	Bundle of Power cable	BOSS FireMastic – HPE™	-	Ø90 mm
	B	Bundle of cables and pipes	BOSS FireMastic – 300™	BOSS Fire Box	300 mm × 80 mm
	C	100 mm UPVC (Sandwich core) pipe	BOSS 100 mm MaxiCollar™ BOSS FireMastic – 300™	-	Ø121mm
	D	Bundle of aluminium cables	BOSS FireMastic – 300™	BOSS Batt BOSS Cable Transit CT120	110 mm × 110 mm
	E	40 mm UPVC pipe	BOSS FireMastic - HPE™	-	Ø44mm
	F	50 mm UPVC pipe	BOSS 50 mm MaxiCollar™ BOSS FireMastic – 300™	-	Ø76mm
	G	80 mm UPVC pipe	BOSS 80 mm MaxiCollar™ BOSS FireMastic – 300™	-	Ø102mm
	H	Bundle of CAT6 data cable	BOSS Firemastic - HPE™	-	Ø90 mm
	I	60 mm galvanised sprinkler pipe	BOSS FireMastic - 300™	-	Ø80 mm
	J	80 mm copper pipe with lagging	BOSS P40-MAK Wrap BOSS 150 mm MaxiCollar™ BOSS FireMastic – 300™	BOSS Batt	Ø180 mm
	K	40 mm UPVC pipe	BOSS 40 mm MaxiCollar™ BOSS FireMastic – 300™	-	Ø70 mm
	L	32mm Pex-a pipe	BOSS FireMastic - HPE™	-	Ø70 mm

Information about test report					
	M	60 mm cPVC pipe	BOSS FireMastic - HPE™	-	Ø102mm
Instrumentation	The test report states that the instrumentation was in accordance with AS 1530.4:2014.				

The test specimen achieved the following results – see Table 64.

Table 88 Results summary for this test report

Penetration system	Service	Local fire-stopping protection	Main fire-stopping protection	Aperture size (mm)	FRL
A	Bundle of Power cables	BOSS FireMastic – HPE™	-	Ø90 mm	-/120/60
B	Bundle of cables and pipes	BOSS FireMastic – 300™	BOSS Fire Box	300 mm × 80 mm	-/120/30
C	100 mm UPVC (Sandwich core) pipe	BOSS 100 mm MaxiCollar™ BOSS FireMastic – 300™	-	Ø121mm	-/120/0
D	Bundle of aluminium cables	BOSS FireMastic – 300™	BOSS Batt BOSS Cable Transit CT120	110 mm × 110 mm	-/120/30
E	40 mm UPVC pipe	BOSS FireMastic - HPE™	-	Ø44mm	-/120/90
F	50 mm UPVC pipe	BOSS 50 mm MaxiCollar™ BOSS FireMastic – 300™	-	Ø76mm	-/120/120
G	80 mm UPVC pipe	BOSS 80 mm MaxiCollar™ BOSS FireMastic – 300™	-	Ø102mm	-/120/120
H	Bundle of CAT6 data cable	BOSS Firemastic - HPE™	-	Ø90 mm	-/120/60
I	60 mm galvanised sprinkler pipe	BOSS FireMastic - 300™	-	Ø80 mm	-/120/90

J	80 mm copper pipe with lagging	BOSS P40-MAK Wrap BOSS 150 mm MaxiCollar™ BOSS FireMastic – 300™	BOSS Batt	Ø180 mm	-/120/120
K	40 mm UPVC pipe	BOSS 40 mm MaxiCollar™ BOSS FireMastic – 300™	-	Ø70 mm	-/120/90
L	32mm PEX-A pipe	BOSS FireMastic - HPE™	-	Ø70 mm	-/120/0
M	60 mm cPVC pipe	BOSS FireMastic - HPE™	-	Ø102mm	-/120/0

A.14 Test report – FP10422-001 Issue 2

Table 89 Information about test report

Item	Information about test report
Report sponsor	The Insulation Contractor Association of Australia Queensland Inc
Test laboratory	1222 Moonshine Rd, RD1, Porirua 5381, Private Bag 50908, Porirua 5240, New Zealand
Test date	The fire resistance test was done on 24 May 2019
Test standards	The test was done in accordance with AS 1530.4:2014
Variation to test standards	None
General description of tested specimen	The specimens consisted of a nominally 2200 mm high by 1000 mm wide by 130 mm thick steel stud wall lined with two layers of 13 mm thick Knauf MultiShield plasterboard on each face. The wall was provided with six apertures and fitted with six pipe penetrations. Each penetration comprised a single pipe insulated with a mineral fibre insulated pipe section. The pipes ranged in diameter from 25 mm to 324 mm OD and the pipe materials were Steel and Copper.
Instrumentation	The test report states that the instrumentation was in accordance with AS 1530.4:2014

The test specimen achieved the following results – see Table 90.

Table 90 Results summary for this test report

Penetration system	Insulation thickness (mm)	Pipe	Criteria	Fire resistance level (FRL)
X1	75	324 mm Ø Steel schedule 40 pipe	Structural adequacy	-/120/120

Penetration system	Insulation thickness (mm)	Pipe	Criteria	Fire resistance level (FRL)
			Integrity	
			Insulation	
X2	50	100 mm Ø Copper pipe	Structural adequacy	-/120/120
			Integrity	
			Insulation	
X3	25	25 mm Ø Copper pipe	Structural adequacy	-/120/90
			Integrity	
			Insulation	
Y1	75	324 mm Ø Steel schedule 40 pipe	Structural adequacy	-/90/90
			Integrity	
			Insulation	
Y2	50	100 mm Ø Copper pipe	Structural adequacy	-/120/60
			Integrity	
			Insulation	
Y3	25	25 mm Ø Copper pipe	Structural adequacy	-/120/120
			Integrity	
			Insulation	

A.15 Test report – FP10422-002 Issue 2

Table 91 Information about test report

Item	Information about test report
Report sponsor	The Insulation Contractor Association of Australia Queensland Inc
Test laboratory	1222 Moonshine Rd, RD1, Porirua 5381, Private Bag 50908, Porirua 5240, New Zealand
Test date	The fire resistance test was done on 22 May 2019
Test standards	The test was done in accordance with AS 1530.4:2014.
Variation to test standards	None
General description of tested specimen	<p>The specimens consisted of a nominally 125 mm thick concrete floor slab. The overall thickness of the concrete floor slab was nominally 120 mm to 130 mm at its thinnest and thickest depths, respectively, and the footprint nominally measured 2200 mm high by 1000 mm wide.</p> <p>The floor was provided with six core drilled apertures and fitted with six pipe penetrations. Each penetration comprised a single pipe insulated with a mineral fibre insulated pipe section. The pipes ranged in diameter from 25 mm to 324 mm OD, and the pipe materials were Steel and Copper.</p>

Item	Information about test report
Instrumentation	The test report states that the instrumentation was in accordance with AS 1530.4:2014.

The test specimen achieved the following results – see Table 92.

Table 92 Results summary for this test report

Penetration system	Insulation thickness (mm)	Pipe	Criteria	Fire resistance level (FRL)
FX1	75	324 mm Ø Steel schedule 40 pipe	Structural adequacy	-/120/120
			Integrity	
			Insulation	
FX2	50	100 mm Ø Copper pipe	Structural adequacy	-/120/90
			Integrity	
			Insulation	
FX3	25	25 mm Ø Copper pipe	Structural adequacy	-/120/120
			Integrity	
			Insulation	
FY1	75	324 mm Ø Steel schedule 40 pipe	Structural adequacy	-/120/120
			Integrity	
			Insulation	
FY2	50	100 mm Ø Copper pipe	Structural adequacy	-/120/60
			Integrity	
			Insulation	
FY3	25	25 mm Ø Copper pipe	Structural adequacy	-/120/120
			Integrity	
			Insulation	

A.16 Test report – WARRES 359904 Issue 2

Table 93 Information about test report

Item	Information about test report
Report sponsor	FSI Limited
Test laboratory	Exova (UK) Ltd, Lochend Industrial Estate, Newbridge, Midlothian EH28 8PL United Kingdom
Test date	The fire resistance test was done on 24 May 2016
Test standards	The test was done in accordance with BS EN 1366-3:2009
Variation to test standards	None

Item	Information about test report
General description of tested specimen	<p>The specimens were referenced as A and B for the purpose of the test, and the penetrations within the specimens were referenced as services A to I in the wall and J to R in the floor.</p> <p>For the vertical wall specimen (Specimen A), the section of the wall had overall dimensions of 1500 mm high by 1500 mm wide by 150 mm thick, was provided with a single aperture measuring 1100 mm long by 750 mm wide and was penetrated with various plastic pipes and cables.</p> <p>For the horizontal floor specimen (Specimen B), the section of the floor had overall dimensions of 2230 mm long by 1740 mm wide by 150 mm thick, was provided with a single aperture measuring 1100 mm long by 750 mm wide, and was penetrated with various plastic pipes and cables.</p>
Instrumentation	The test report states that the instrumentation was in accordance with BS EN 1366-3:2009

The test specimen achieved the following results – see Table 94.

Table 94 Results summary for this test report

Penetration system	Details	Criteria	Fire resistance level (FRL)
A	500 mm perforated tray	Structural adequacy	-/120/120
		Integrity	
		Insulation	
	A1	Structural adequacy	-/120/120
		Integrity	
		Insulation	
	A2	Structural adequacy	-/120/120
		Integrity	
		Insulation	
	A3	Structural adequacy	-/120/120
		Integrity	
		Insulation	
	B	Structural adequacy	-/120/120
		Integrity	
		Insulation	
	C1	Structural adequacy	-/120/120
		Integrity	
		Insulation	
	C2	Structural adequacy	-/120/90
		Integrity	
		Insulation	
	C3	Structural adequacy	-/120/120
		Integrity	
		Insulation	

Penetration system	Details	Criteria	Fire resistance level (FRL)
B	PEX pipe 40 mm 4 mm	Structural adequacy	-/120/120
		Integrity	
		Insulation	
C	Copper pipe 42 mm 1.2	Structural adequacy	-/120/60
		Integrity	
		Insulation	
D	PVC-u pipe, 50 mm 2.4 mm	Structural adequacy	-/120/120
		Integrity	
		Insulation	
E	Copper pipe 159 mm 2	Structural adequacy	-/120/30
		Integrity	
		Insulation	
F	PVC-u pipe, 50 mm 3.7 mm	Structural adequacy	-/120/120
		Integrity	
		Insulation	
G	PEX pipe 110 mm 10 mm	Structural adequacy	-/120/120
		Integrity	
		Insulation	
H	PVC-u pipe, 125 mm 4.8 mm	Structural adequacy	-/120/90
		Integrity	
		Insulation	
I	PVC-u pipe, 125 mm 7.4 mm	Structural adequacy	-/120/120
		Integrity	
		Insulation	
Overall seal	-	Structural adequacy	-/120/120
		Integrity	
		Insulation	

A.17 Test report – WARRES 342026 Issue 2

Table 95 Information about test report

Item	Information about test report
Report sponsor	FSI Limited
Test laboratory	Exova (UK) Ltd, Lochend Industrial Estate, Newbridge, Midlothian EH28 8PL United Kingdom
Test date	The fire resistance test was done on 5 August 2014
Test standards	The test was done in accordance with BS EN 1366-3:2009
Variation to test standards	None

Item	Information about test report
General description of tested specimen	The section of floor had overall dimensions of 2230 mm long by 1740 mm wide by 150 mm thick and was provided with ten circular apertures of varying sizes, each penetrated with various plastic pipes and one copper pipe. There were also three square apertures of varying sizes with various services and cables passing through, and one blank seal.
Instrumentation	The test report states that the instrumentation was in accordance with BS EN 1366-3:2009

The test specimen achieved the following results – see Table 96.

Table 96 Results summary for this test report

Details	Criteria	Fire resistance level (FRL)
A	Structural adequacy	-/30/30
	Integrity	
	Insulation	
B	Structural adequacy	-/120/120
	Integrity	
	Insulation	
C	Structural adequacy	-/240/240
	Integrity	
	Insulation	
D	Structural adequacy	-/240/240
	Integrity	
	Insulation	
E	Structural adequacy	-/60/60
	Integrity	
	Insulation	
F	Structural adequacy	-/90/90
	Integrity	
	Insulation	
G	Structural adequacy	-/240/240
	Integrity	
	Insulation	
H	Structural adequacy	-/90/30
	Integrity	
	Insulation	
I	Structural adequacy	-/120/30
	Integrity	
	Insulation	
J	Structural adequacy	-/240/60
	Integrity	
	Insulation	

Details	Criteria	Fire resistance level (FRL)
K	Structural adequacy	-/120/90
	Integrity	
	Insulation	
L	Structural adequacy	-/240/30
	Integrity	
	Insulation	
M	Structural adequacy	-/240/180
	Integrity	
	Insulation	

A.18 Test report – WARRES 334037-A

Table 97 Information about test report

Item	Information about test report
Report sponsor	FSI Limited
Test laboratory	Exova (UK) Ltd, Lochend Industrial Estate, Newbridge, Midlothian EH28 8PL United Kingdom
Test date	The fire resistance test was done on 28 November 2013
Test standards	The test was done in accordance with BS EN 1366-3:2009
Variation to test standards	None
General description of tested specimen	The drywall construction was of an overall dimension of 3000 mm wide by 3000 mm high by 100 mm thick. The framing comprised 50 mm wide galvanised mild steel studs, at maximum 600 mm centres, friction fitted into galvanised steel head and base channels. Each side of the stud frame was faced with two layers of 12.5 mm thick gypsum Type F plasterboard. The framework was infilled with 50 mm thick mineral wool insulation with a nominal density of 100 kg/m ³ . The wall were provided with eight circular apertures, which was penetrated by a range of shower units.
Instrumentation	The test report states that the instrumentation was in accordance with BS EN 1366-3:2009

The test specimen achieved the following results – see Table 98

Table 98 Results summary for this test report

Details	Criteria	Fire resistance level (FRL)
13	Structural adequacy	-/120/120
	Integrity	
	Insulation	
14	Structural adequacy	-/120/120
	Integrity	
	Insulation	
15	Structural adequacy	-/120/120
	Integrity	

Details	Criteria	Fire resistance level (FRL)
	Insulation	
16	Structural adequacy	-/120/120
	Integrity	
	Insulation	

A.19 Test report – WARRES 334037-D

Table 99 Information about test report

Item	Information about test report
Report sponsor	FSI Limited
Test laboratory	Exova (UK) Ltd, Lochend Industrial Estate, Newbridge, Midlothian EH28 8PL United Kingdom
Test date	The fire resistance test was done on 28 November 2013
Test standards	The test was done in accordance with BS EN 1366-3:2009
Variation to test standards	None
General description of tested specimen	The drywall construction was of an overall dimension of 3000 mm wide by 3000 mm high by 100 mm thick. The framing comprised 50 mm wide galvanised mild steel studs, at maximum 600 mm centres, friction fitted into galvanised steel head and base channels. Each side of the stud frame was faced with two layers of 12.5 mm thick gypsum Type F plasterboard. The framework was infilled with 50 mm thick mineral wool insulation with a nominal density of 100 kg/m ³ . The wall was provided with fifteen circular apertures. Twelve of the circular apertures were penetrated by a range of PVC, PE, PP and ABS pipes. The remaining three circular apertures were penetrated by an insulated copper pipe.
Instrumentation	The test report states that the instrumentation was in accordance with BS EN 1366-3:2009

The test specimen achieved the following results – see Table 100.

Table 100 Results summary for this test report

Details	Criteria	Fire resistance level (FRL)
1	Structural adequacy	-/60/60
	Integrity	
	Insulation	
2	Structural adequacy	-/30/30
	Integrity	
	Insulation	
3	Structural adequacy	-/120/120
	Integrity	
	Insulation	
4	Structural adequacy	-/30/30
	Integrity	

Details	Criteria	Fire resistance level (FRL)
	Insulation	
5	Structural adequacy	-/0/0
	Integrity	
	Insulation	
6	Structural adequacy	-/30/30
	Integrity	
	Insulation	
7	Structural adequacy	-/0/0
	Integrity	
	Insulation	
8	Structural adequacy	-/0/0
	Integrity	
	Insulation	
9	Structural adequacy	-/120/120
	Integrity	
	Insulation	
10	Structural adequacy	-/120/30
	Integrity	
	Insulation	
11	Structural adequacy	-/120/30
	Integrity	
	Insulation	
12	Structural adequacy	-/120/30
	Integrity	
	Insulation	
18	Structural adequacy	-/120/120
	Integrity	
	Insulation	
19	Structural adequacy	-/0/0
	Integrity	
	Insulation	
20	Structural adequacy	-/0/0
	Integrity	
	Insulation	

A.20 Test report – WF 342025

Table 101 Information about test report

Item	Information about test report
Report sponsor	FSI Limited

Item	Information about test report
Test laboratory	Exova (UK) Ltd, Lochend Industrial Estate, Newbridge, Midlothian EH28 8PL United Kingdom
Test date	The fire resistance test was done on 25 June 2014
Test standards	The test was done in accordance with BS EN 1366-3:2009
Variation to test standards	None
General description of tested specimen	The section of floor had overall dimensions of 2230 mm long by 1740 mm wide by 150 mm thick and was provided with five 200 mm by 200 mm apertures and one 50 mm by 50 mm aperture, each penetrated with various cables and services. The floor was also provided with four circular apertures, each penetrated by a range of insulated steel and copper pipes.
Instrumentation	The test report states that the instrumentation was in accordance with BS EN 1366-3:2009

The test specimen achieved the following results – see Table 102.

Table 102 Results summary for this test report

Details	Criteria	Fire resistance level (FRL)
A	Structural adequacy	-/180/30
	Integrity	
	Insulation	
B	Structural adequacy	-/120/30
	Integrity	
	Insulation	
C	Structural adequacy	-/180/30
	Integrity	
	Insulation	
D	Structural adequacy	-/0/0
	Integrity	
	Insulation	
E	Structural adequacy	-/30/30
	Integrity	
	Insulation	
F	Structural adequacy	-/120/30
	Integrity	
	Insulation	
G	Structural adequacy	-/180/0
	Integrity	
	Insulation	
H	Structural adequacy	-/30/0
	Integrity	
	Insulation	
I	Structural adequacy	-/0/0

Details	Criteria	Fire resistance level (FRL)
	Integrity	
	Insulation	
J	Structural adequacy	-/240/0
	Integrity	
	Insulation	

A.21 Test report – WF 359902

Table 103 Information about test report

Item	Information about test report
Report sponsor	FSI Limited
Test laboratory	Exova (UK) Ltd, Lochend Industrial Estate, Newbridge, Midlothian EH28 8PL United Kingdom
Test date	The fire resistance test was done on 25 June 2014
Test standards	The test was done in accordance with BS EN 1366-3:2009
Variation to test standards	None
General description of tested specimen	The section of wall had overall dimensions of 1500 mm high by 1500 mm wide by 150 mm thick and was provided with a single aperture measuring 1100 mm long by 750 mm wide. It was penetrated by eight various pipes of various sizes and compositions and a single cable tray carrying various sizes of cables as specified in Annexe B of BS EN 1366-3:2009.
Instrumentation	The test report states that the instrumentation was in accordance with BS EN 1366-3:2009

The test specimen achieved the following results – see Table 104.

Table 104 Results summary for this test report

Penetration system	Details	Criteria	Fire resistance level (FRL)
A	500 mm perforated tray	Structural adequacy	-/30/30
		Integrity	
		Insulation	
	A1	Structural adequacy	-/30/30
		Integrity	
		Insulation	
	A2	Structural adequacy	-/30/30
		Integrity	
		Insulation	
	A3	Structural adequacy	-/30/30
		Integrity	
		Insulation	
B	Structural adequacy	-/30/30	
	Integrity		

Penetration system	Details	Criteria	Fire resistance level (FRL)
	C1	Insulation	-/30/30
		Structural adequacy	
		Integrity	
	C2	Insulation	-/30/30
		Structural adequacy	
		Integrity	
	C3	Insulation	-/30/30
		Structural adequacy	
		Integrity	
B	PEX pipe 40 mm by 4 mm	Structural adequacy	-/30/30
		Integrity	
		Insulation	
C	Copper pipe 42 mm by 1.2 mm	Structural adequacy	-/30/30
		Integrity	
		Insulation	
D	PVC-u pipe, 50 mm by 2.4 mm	Structural adequacy	-/30/30
		Integrity	
		Insulation	
E	Copper pipe 159 mm 2 mm	Structural adequacy	-/30/0
		Integrity	
		Insulation	
F	PVC-u pipe, 50 mm by 3.7 mm	Structural adequacy	-/30/30
		Integrity	
		Insulation	
G	PEX pipe 110 mm by 10 mm	Structural adequacy	-/30/30
		Integrity	
		Insulation	
H	PVC-u pipe, 125 mm by 4.8 mm	Structural adequacy	-/30/30
		Integrity	
		Insulation	
I	PVC-u pipe, 125 mm by 7.4 mm	Structural adequacy	-/30/30
		Integrity	
		Insulation	
Overall seal	-	Structural adequacy	-/30/30
		Integrity	
		Insulation	

A.22 Test report – WF 329129

Table 105 Information about test report

Item	Information about test report
Report sponsor	FSI Limited
Test laboratory	Exova (UK) Ltd, Lochend Industrial Estate, Newbridge, Midlothian EH28 8PL United Kingdom
Test date	The fire resistance test was done on 25 June 2014
Test standards	The test was done in accordance with BS EN 1366-3:2009
Variation to test standards	None
General description of tested specimen	The drywall construction was of an overall dimension of 3000 mm wide by 3000 mm high by 100 mm thick. The framing comprised 50 mm wide galvanised mild steel studs, at maximum 600 mm centres, friction fitted into galvanised steel head and base channels. Each side of the stud frame was faced with two layers of 12.5 mm thick Gyprock Fireline plasterboard. The framework was infilled with 50 mm thick mineral wool insulation with a nominal density of 100 kg/m ³ . The wall was provided with four apertures, each of overall nominal dimensions 600 mm high by 600 mm wide. The aperture around specimens B and D was framed and lined with a single layer of 12.5 mm thick Gyprock Fireline plasterboard. Two of the apertures was penetrated by two cable trays and two ladders, each carrying various sizes of cables as specified in Annex B of BS EN 1366-3:2009. The apertures were sealed using a range of ablative coated batt.
Instrumentation	The test report states that the instrumentation was in accordance with BS EN 1366-3:2009

The test specimen achieved the following results – see Table 106.

Table 106 Results summary for this test report

Service reference	Criteria	Fire resistance level (FRL)
Specimen A		
Pipe 1	Structural adequacy	-/60/30
	Integrity	
	Insulation	
Pipe 2	Structural adequacy	-/60/60
	Integrity	
	Insulation	
Pipe 3	Structural adequacy	-/60/60
	Integrity	
	Insulation	
Pipe 4	Structural adequacy	-/60/60
	Integrity	
	Insulation	
Overall seal	Structural adequacy	-/60/30
	Integrity	

Service reference	Criteria	Fire resistance level (FRL)
	Insulation	
Specimen B		
Pipe 1	Structural adequacy	-/60/60
	Integrity	
	Insulation	
Pipe 2	Structural adequacy	-/90/60
	Integrity	
	Insulation	
Pipe 3	Structural adequacy	-/90/60
	Integrity	
	Insulation	
Pipe 4	Structural adequacy	-/60/60
	Integrity	
	Insulation	
Overall seal	Structural adequacy	-/60/60
	Integrity	
	Insulation	
Specimen C		
350 mm ladder	Structural adequacy	-/60/60
	Integrity	
	Insulation	
D1	Structural adequacy	-/60/60
	Integrity	
	Insulation	
D2	Structural adequacy	-/60/60
	Integrity	
	Insulation	
E	Structural adequacy	-/60/30
	Integrity	
	Insulation	
250 mm ladder	Structural adequacy	-/60/60
	Integrity	
	Insulation	
D3	Structural adequacy	-/60/30
	Integrity	
	Insulation	
450 mm perforated tray	Structural adequacy	-/60/60
	Integrity	
	Insulation	
A1	Structural adequacy	-/60/60

Service reference	Criteria	Fire resistance level (FRL)
	Integrity	
	Insulation	
A2	Structural adequacy	-/60/60
	Integrity	
	Insulation	
A3	Structural adequacy	-/60/60
	Integrity	
	Insulation	
B	Structural adequacy	-/60/60
	Integrity	
	Insulation	
C1	Structural adequacy	-/60/60
	Integrity	
	Insulation	
C2	Structural adequacy	-/60/60
	Integrity	
	Insulation	
C3	Structural adequacy	-/60/30
	Integrity	
	Insulation	
500 mm non-perforated tray	Structural adequacy	-/60/60
	Integrity	
	Insulation	
F	Structural adequacy	-/60/60
	Integrity	
	Insulation	
G1	Structural adequacy	-/60/0
	Integrity	
	Insulation	
G2	Structural adequacy	-/60/30
	Integrity	
	Insulation	
I	Structural adequacy	-/60/60
	Integrity	
	Insulation	
H3	Structural adequacy	-/60/0
	Integrity	
	Insulation	
Overall seal	Structural adequacy	-/60/0
	Integrity	

Service reference	Criteria	Fire resistance level (FRL)
	Insulation	
Specimen D		
350 mm ladder	Structural adequacy	-/60/60
	Integrity	
	Insulation	
D1	Structural adequacy	-/60/60
	Integrity	
	Insulation	
D2	Structural adequacy	-/60/60
	Integrity	
	Insulation	
E	Structural adequacy	-/60/30
	Integrity	
	Insulation	
250 mm ladder	Structural adequacy	-/60/60
	Integrity	
	Insulation	
D3	Structural adequacy	-/60/60
	Integrity	
	Insulation	
450 mm perforated tray	Structural adequacy	-/60/60
	Integrity	
	Insulation	
A1	Structural adequacy	-/90/90
	Integrity	
	Insulation	
A2	Structural adequacy	-/60/60
	Integrity	
	Insulation	
A3	Structural adequacy	-/60/60
	Integrity	
	Insulation	
B	Structural adequacy	-/60/60
	Integrity	
	Insulation	
C1	Structural adequacy	-/60/60
	Integrity	
	Insulation	
C2	Structural adequacy	-/60/60
	Integrity	

Service reference	Criteria	Fire resistance level (FRL)
	Insulation	
C3	Structural adequacy	-/60/60
	Integrity	
	Insulation	
500 mm non-perforated tray	Structural adequacy	-/60/60
	Integrity	
	Insulation	
F	Structural adequacy	-/60/60
	Integrity	
	Insulation	
G1	Structural adequacy	-/60/30
	Integrity	
	Insulation	
G2	Structural adequacy	-/60/0
	Integrity	
	Insulation	
I	Structural adequacy	-/60/60
	Integrity	
	Insulation	
H3	Structural adequacy	-/60/0
	Integrity	
	Insulation	
Overall seal	Structural adequacy	-/60/0
	Integrity	
	Insulation	

A.23 Test report – 55693000.2

Table 107 Information about test report

Item	Information about test report
Report sponsor	Boss Fire (Australia) Pty Ltd
Test laboratory	Warringtonfire, Unit 2, 409-411 Hammond Road, Dandenong Victoria 3175, Australia
Test date	The fire resistance test was done on 6 August 2018
Test standards	The test was done in accordance with AS 1530.4:2014
Variation to test standards	None

Item	Information about test report																																																																																																		
General description of tested specimen	<p>The test specimen comprised a 92 mm thick steel frame system clad with two layers of 13 mm USG Boral Firestop plasterboard on both exposed and unexposed sides. The wall cavity was filled with Fletcher Insulation Pink Partition 14 R2.2 insulation.</p> <p>There was a 20 mm gap between the test frame and the top edge of the plasterboard, a 15 mm gap between the test frame and the vertical edge of the plasterboard, and a 10 mm gap between the test frame and the bottom edge of the plasterboard. The gaps were protected by BOSS FM300 sealant.</p> <p>The wall system was penetrated by 12-off various pipe services and 1-off cable services. The pipe and cable services were protected by various fire protection systems. The test assembly is summarised in the table below.</p> <table border="1"> <thead> <tr> <th>Service No.</th> <th>Service</th> <th>Service size (mm)</th> <th>Core hole Size (mm)</th> <th>No. of service/s</th> <th>Local Fire Protection</th> <th>Secondary Fire protection</th> </tr> </thead> <tbody> <tr> <td>1</td> <td>PEX/AL/PEX</td> <td>Ø25</td> <td>65</td> <td>1</td> <td>FireMastic-HPE</td> <td>None</td> </tr> <tr> <td>2</td> <td>PEX pipe</td> <td>Ø 25</td> <td>65</td> <td>1</td> <td>FireMastic-HPE</td> <td>None</td> </tr> <tr> <td>3</td> <td>PEX pipe</td> <td>Ø 25</td> <td>32</td> <td>1</td> <td>BOSS 32mm MaxiCollar™</td> <td>FireMastic-HPE</td> </tr> <tr> <td>4</td> <td>CPVC pipe</td> <td>Ø 50</td> <td>90</td> <td>1</td> <td>FireMastic-HPE</td> <td>None</td> </tr> <tr> <td>5</td> <td>PEX pipe</td> <td>Ø 32</td> <td>72</td> <td>1</td> <td>FireMastic-HPE</td> <td>None</td> </tr> <tr> <td>6</td> <td>UPVC pipe</td> <td>Ø 40</td> <td>80</td> <td>1</td> <td>FireMastic-HPE</td> <td>None</td> </tr> <tr> <td>7</td> <td>UPVC pipe</td> <td>Ø 50</td> <td>90</td> <td>1</td> <td>FireMastic-HPE</td> <td>None</td> </tr> <tr> <td>8</td> <td>Galvanised pipe</td> <td>Ø34</td> <td>42</td> <td>1</td> <td>BOSS FM300</td> <td>None</td> </tr> <tr> <td>9</td> <td>TPS cables</td> <td>12 × 5.6</td> <td>30</td> <td>7</td> <td>BOSS FM300</td> <td>None</td> </tr> <tr> <td>10</td> <td>UPVC pipe</td> <td>Ø80</td> <td>120</td> <td>1</td> <td>FireMastic-HPE</td> <td>None</td> </tr> <tr> <td>11</td> <td>UPVC pipe</td> <td>Ø100</td> <td>110</td> <td>1</td> <td>BOSS 100 mm MaxiCollar™</td> <td>None</td> </tr> <tr> <td>12</td> <td>PP-R pipe</td> <td>Ø63</td> <td>103</td> <td>1</td> <td>FireMastic-HPE</td> <td>None</td> </tr> <tr> <td>13</td> <td><i>PP-R pipe</i></td> <td><i>Ø50</i></td> <td><i>90</i></td> <td><i>1</i></td> <td><i>FireMastic-HPE</i></td> <td><i>None</i></td> </tr> </tbody> </table>	Service No.	Service	Service size (mm)	Core hole Size (mm)	No. of service/s	Local Fire Protection	Secondary Fire protection	1	PEX/AL/PEX	Ø25	65	1	FireMastic-HPE	None	2	PEX pipe	Ø 25	65	1	FireMastic-HPE	None	3	PEX pipe	Ø 25	32	1	BOSS 32mm MaxiCollar™	FireMastic-HPE	4	CPVC pipe	Ø 50	90	1	FireMastic-HPE	None	5	PEX pipe	Ø 32	72	1	FireMastic-HPE	None	6	UPVC pipe	Ø 40	80	1	FireMastic-HPE	None	7	UPVC pipe	Ø 50	90	1	FireMastic-HPE	None	8	Galvanised pipe	Ø34	42	1	BOSS FM300	None	9	TPS cables	12 × 5.6	30	7	BOSS FM300	None	10	UPVC pipe	Ø80	120	1	FireMastic-HPE	None	11	UPVC pipe	Ø100	110	1	BOSS 100 mm MaxiCollar™	None	12	PP-R pipe	Ø63	103	1	FireMastic-HPE	None	13	<i>PP-R pipe</i>	<i>Ø50</i>	<i>90</i>	<i>1</i>	<i>FireMastic-HPE</i>	<i>None</i>
Service No.	Service	Service size (mm)	Core hole Size (mm)	No. of service/s	Local Fire Protection	Secondary Fire protection																																																																																													
1	PEX/AL/PEX	Ø25	65	1	FireMastic-HPE	None																																																																																													
2	PEX pipe	Ø 25	65	1	FireMastic-HPE	None																																																																																													
3	PEX pipe	Ø 25	32	1	BOSS 32mm MaxiCollar™	FireMastic-HPE																																																																																													
4	CPVC pipe	Ø 50	90	1	FireMastic-HPE	None																																																																																													
5	PEX pipe	Ø 32	72	1	FireMastic-HPE	None																																																																																													
6	UPVC pipe	Ø 40	80	1	FireMastic-HPE	None																																																																																													
7	UPVC pipe	Ø 50	90	1	FireMastic-HPE	None																																																																																													
8	Galvanised pipe	Ø34	42	1	BOSS FM300	None																																																																																													
9	TPS cables	12 × 5.6	30	7	BOSS FM300	None																																																																																													
10	UPVC pipe	Ø80	120	1	FireMastic-HPE	None																																																																																													
11	UPVC pipe	Ø100	110	1	BOSS 100 mm MaxiCollar™	None																																																																																													
12	PP-R pipe	Ø63	103	1	FireMastic-HPE	None																																																																																													
13	<i>PP-R pipe</i>	<i>Ø50</i>	<i>90</i>	<i>1</i>	<i>FireMastic-HPE</i>	<i>None</i>																																																																																													
Instrumentation	The test report states that the instrumentation was in accordance with AS 1530.4:2014																																																																																																		

The test specimen achieved the following results – see Table 108.

Table 108 Results summary for this test report

Service	Criteria	Result
1	Structural Adequacy	-
	Integrity	No failure at 121 minutes

Service	Criteria	Result
	Insulation	Failure at 47 minutes
	FRL	-/120/30
2	Structural Adequacy	-
	Integrity	No failure at 121 minutes
	Insulation	No failure at 121 minutes
	FRL	-/120/120
3	Structural Adequacy	-
	Integrity	No failure at 121 minutes
	Insulation	Failure at 78 minutes
	FRL	-/120/60
4	Structural Adequacy	-
	Integrity	No failure at 121 minutes
	Insulation	Failure at 65 minutes
	FRL	-/120/60
5	Structural Adequacy	-
	Integrity	No failure at 121 minutes
	Insulation	Failure at 9 minutes
	FRL	-/120/0
6	Structural Adequacy	-
	Integrity	No failure at 121 minutes
	Insulation	No failure at 121 minutes
	FRL	-/120/120
7	Structural Adequacy	-
	Integrity	No failure at 121 minutes
	Insulation	No failure at 121 minutes
	FRL	-/120/120
8	Structural Adequacy	-
	Integrity	No failure at 121 minutes
	Insulation	No failure at 121 minutes
	FRL	-/120/120
9	Structural Adequacy	-
	Integrity	No failure at 121 minutes
	Insulation	No failure at 121 minutes
	FRL	-/120/120
10	Structural Adequacy	-
	Integrity	Failure at 113 minutes
	Insulation	Failure at 113 minutes
	FRL	-/90/90

Service	Criteria	Result
11	Structural Adequacy	-
	Integrity	No failure at 121 minutes
	Insulation	No failure at 121 minutes
	FRL	-/120/120
12	Structural Adequacy	-
	Integrity	No failure at 121 minutes
	Insulation	Failure at 15 minutes
	FRL	-/120/0
13	Structural Adequacy	-
	Integrity	No failure at 121 minutes
	Insulation	Failure at 10 minutes
	FRL	-/120/0

A.24 Test report – 49599300.7

Table 109 Information about test report

Item	Information about test report
Report sponsor	Boss fire and safety Pty Ltd
Test laboratory	Warringtonfire, Unit 2, 409-411 Hammond Road, Dandenong Victoria 3175, Australia
Test date	The fire resistance test was done on 22 February 2019
Test standards	The test was done in accordance with AS 1530.4:2014
Variation to test standards	None
General description of tested specimen	Boss FireMastic-HPE sealant protecting PE-X, PE-X AL pipes, bundle of paircoil, cables and PVC conduit penetrations in Plasterboard lined walls, concrete, Speedpanel, 75mm Hebel reinforced AAC panel and solid or hollow masonry walls.
Instrumentation	The test report states that the instrumentation was in accordance with AS 1530.4:2014

The test specimen achieved the following results – see Table 110.

Table 110 Results summary for this test report

	Service	Fire protection	Aperture size	Wall Separating Element	FRL
A1	Insulated paircoil, TPS cable and data cable and Up to 20 mm OD PVC conduit	Boss FireMastic-HPE sealant to a nominal Depth of 25 mm controlled by foam backing rod. Sealant finished with a	Up to 125 mm in diameter	Fire rated plasterboard lined walls,concrete,Speedpanel, 75mm Hebel or reinforced AAC panel and solid or hollow masonry walls	-/120/120
A2	TPS cable and data cable, Up to				

	Service	Fire protection	Aperture size	Wall Separating Element	FRL
	20 mm OD PVC conduit, 3 x Up to 20 mm insulated copper pipes	nominal 25 mm fillet.		Fire rated plasterboard lined walls, concrete, Speedpanel, 75mm Hebel or reinforced AAC panel and solid or hollow masonry walls	
B	Insulated paircoil, TPS cable and data cable		Up to 100 mm in diameter		-/120/120
C	PE-X pipes Up to 20 mm OD x 2.4mm-3.0 mm pipe wall thickness	Annular gap sealed with Boss FireMastic-HPE sealant to a nominal depth of 25 mm controlled by foam backing rod. Sealant flush with the face of the wall on both sides.	Up to 60 mm in diameter		-/120/120
D	PE-X AL pipes Up to 20 mm OD x 2.8mm-3.0 mm pipe wall thickness				-/120/120
E	cPVC pipes Up to 43mm OD x 3.5mm pipe wall thickness	Annular gap sealed with FireMastic-HPE sealant to a nominal depth of 25 mm controlled by foam backing rod. Sealant finished with a nominal 15mm fillet with the face of the wall on both sides.	Up to 80 mm in diameter		-/120/120
F	UPVC or 'P23 NBN' pipes Up to 25 mm OD x 2mm pipe wall thickness	Gap around the pipe sealed with FireMastic-HPE sealant as possible. Sealant finished with a nominal 20 mm surface fillet with the face of the wall on both sides.	25 mm in diameter		-/120/120
G	UPVC or 'NBN' pipes Up to 20 mm OD x 2mm pipe wall thickness	Gap around the pipe sealed with FireMastic-HPE sealant as possible. Sealant finished with a nominal 15mm surface fillet with the face of the wall on both sides.	20 mm in diameter		-/120/120

A.25 Test report – 371239

Table 111 Information about test report

Item	Information about test report
Report sponsor	Boss fire and safety Pty Ltd
Test laboratory	Warringtonfire, Unit 2, 409-411 Hammond Road, Dandenong Victoria 3175, Australia
Test date	The fire resistance test was done on 28 September 2016
Test standards	The test was done in accordance with BS EN 1366-3:2009
Variation to test standards	None
General description of tested specimen	The section of wall had overall dimensions of 1500 mm high by 1500 mm wide by 150 mm thick and was provided with six 180 mm high by 180 mm wide apertures (Specimens A to F) and a single 50 mm high by 50 mm wide aperture (Specimen G). All the apertures were sealed using a 25 mm depth of a sealant identical to Firematsic -HPE. The sealant was applied flush with each face of the wall with a 20 mm deep Rockwool backing for Specimens A to F and a 25 mm deep Rockwool backing for Specimen G. Specimens B to G carried various sizes of cables.
Instrumentation	The test report states that the instrumentation was in accordance with BS EN 1366-3:2009

The test specimen achieved the following results – see Table 112.

Table 112 Results summary for this test report

Service reference	Criteria	Fire resistance level (FRL)
A	Structural adequacy	-/240/2410
	Integrity	
	Insulation	
B	Structural adequacy	-/240/90
	Integrity	
	Insulation	
C	Structural adequacy	-/240/90
	Integrity	
	Insulation	
D	Structural adequacy	-/180/30
	Integrity	
	Insulation	
E	Structural adequacy	-/240/30
	Integrity	
	Insulation	
F	Structural adequacy	-/240/60
	Integrity	

Service reference	Criteria	Fire resistance level (FRL)
	Insulation	
G	Structural adequacy	-/240/60
	Integrity	
	Insulation	

A.26 Test report – FSP 1791

Table 113 Information about test report

Item	Information about test report
Report sponsor	Boss fire and safety Pty Ltd
Test laboratory	Infrastructure Technologies, 14 Julius Avenue, North Ryde NSW 2113 Australia
Test date	The fire resistance test was conducted on 24 January 2017
Test standards	The test was done in accordance with AS 1530.4:2014
Variation to test standards	None

Item	Information about test report
General description of tested specimen	<p>The specimens comprised eight (8) services penetrating a plasterboard wall and protected by sealants. For the purpose of the test, the specimens were referenced as Specimen 1, 2, 3, 4, 5, 6,7 and 8.</p> <p>Specimen 1 had a 60 mm ID opening in a 90 mm thick wall – PEX cross Linked Polyethylene plumbing pipe. The service penetrated the non-exposed side by 2000 mm and the exposed side by 500 mm.</p> <p>Specimen 2 had an 80 mm ID opening in a 90 mm thick wall – Bundle of paircoil, uPVC drain and Cable in a One-Sided System. The PVC pipe extends 2000 mm from the non-exposed side and all pipes and cable extend 500 mm down into the wall cavity.</p> <p>Specimen 3 had an 80 mm ID opening in a 90 mm thick wall – Bundle of Paircoil, Power Cable and Control Cable sealed with FireMastic-HPE. The services penetrated each side of the wall by 500 mm of PVC conduit.</p> <p>Specimen 4 had an 80 mm ID opening in a 90 mm thick wall – Bundle of Paircoil, Power Cable and Control PVC Cable sealed with a BOSS MaxiCollar. The services penetrated each side of the wall by 500 mm.</p> <p>Specimen 5 had an 8 mm ID opening in a 90 mm thick wall – Single core NBN cable – marking on heath – OFS OPTICAL CABLE IO30-001E-WDW NBN CO SMOF G.657.A2 01/2016 PC9-023162001 LSZH IEC 60332-3C IEC 61034-2. The cable penetrated each side of the wall by 500 mm.</p> <p>Specimen 6 had a 60 mm ID opening in a 90 mm thick wall – Bundle of eight power cables.</p> <p>Specimen 7 had a 60 mm ID opening in a 90 mm thick wall – PEX Cross Linked Polyethylene plumbing pipe. The service penetrated the non-exposed side by 2000 mm and the exposed side by 500 mm.</p> <p>Specimen 8 had an 8-mm ID opening in a 90 mm thick wall – Single core fibre optic cable 20 mm protected with a fillet of FireMastic-HPE on the exposed side only.</p>
Instrumentation	The test report states that the instrumentation was in accordance with AS 1530.4:2014

The test specimen achieved the following results – see Table 110.

Table 114 Results summary for this test report

Service reference	Criteria	Fire resistance level (FRL)
Specimen 1	Structural adequacy	-/60/60
	Integrity	
	Insulation	
Specimen 2	Structural adequacy	-/60/60
	Integrity	
	Insulation	
Specimen 3	Structural adequacy	-/60/60
	Integrity	

Service reference	Criteria	Fire resistance level (FRL)
	Insulation	
Specimen 4	Structural adequacy	-/60/60
	Integrity	
	Insulation	
Specimen 5	Structural adequacy	-/60/60
	Integrity	
	Insulation	
Specimen 6	Structural adequacy	-/60/60
	Integrity	
	Insulation	
Specimen 7	Structural adequacy	-/60/60
	Integrity	
	Insulation	
Specimen 8	Structural adequacy	-/60/60
	Integrity	
	Insulation	

A.27 Test report – FSP 1833

Table 115 Information about test report

Item	Information about test report
Report sponsor	Boss fire and safety Pty Ltd
Test laboratory	Infrastructure Technologies, 14 Julius Avenue, North Ryde NSW 2113 Australia
Test date	The fire resistance test was conducted on 9 May 2017
Test standards	The test was done in accordance with AS 1530.4:2014
Variation to test standards	None
General description of tested specimen	Specimen 1 – FireMastic - HPE sealant protecting a 60 mm diameter aperture penetrated by 20 mm PEX cross linked Polyethylene plumbing pipe
Instrumentation	The test report states that the instrumentation was in accordance with AS 1530.4:2014

Table 116 Results summary for this test report

Service reference	Criteria	Fire resistance level (FRL)
Specimen 1	Structural adequacy	-/90/90
	Integrity	
	Insulation	

A.28 Test report – FSP 2053

Table 117 Information about test report

Item	Information about test report
Report sponsor	Knauf Plasterboard Pty Ltd
Test laboratory	Infrastructure Technologies, 14 Julius Avenue, North Ryde NSW 2113 Australia
Test date	The fire resistance test was conducted on 21 st October 2019
Test standards	The test was done in accordance with AS 1530.4:2014
Variation to test standards	None
General description of tested specimen	Specimen 1 – A 20 mm diameter PE-Xa Rehau Rautitan pipe incorporating an elbow joint in the wall cavity penetrating a 55 mm aperture on the exposed face protected with Fire Mastic – HPE sealant
Instrumentation	The test report states that the instrumentation was in accordance with AS 1530.4:2014

Table 118 Results summary for this test report

Service reference	Criteria	Fire resistance level (FRL)
Specimen 1	Structural adequacy	-/90/90
	Integrity	
	Insulation	

A.29 Test report – EWFA 37995200.3

Table 119 Information about test report

Item	Information about test report
Report sponsor	BROOKFIELD MULTIPLEX Australasia
Test laboratory	Exova Warringtonfire, Unit 2, 409-411 Hammond Road, Dandenong Victoria 3175, Australia
Test date	The fire resistance test was conducted on 14 December 2015
Test standards	The test was done in accordance with AS 1530.4:2005
Variation to test standards	None

Item	Information about test report
General description of tested specimen	Specimen F: Penetrating Service: <ul style="list-style-type: none"> • InterLINK Fire Retardant PairCoil with 9.5 mm diameter and 15.8 mm diameter copper pipe and lagging • Nexans Olex WK32 2015 V90 Electric cable • Electra cables 2015 EAS7501P cable V-90 RoHS Opening: 80 mm diameter Main fire stopping system: <ul style="list-style-type: none"> • 16 mm Knauf Fireshield board with BOSS FireMastic – 300 Local fire stopping system <ul style="list-style-type: none"> • FireMastic HPE
Instrumentation	The test report states that the instrumentation was in accordance with AS 1530.4:2005

Table 120 Results summary for this test report

Service reference	Criteria	Fire resistance level (FRL)
Specimen 1	Structural adequacy	-/90/90
	Integrity	
	Insulation	